

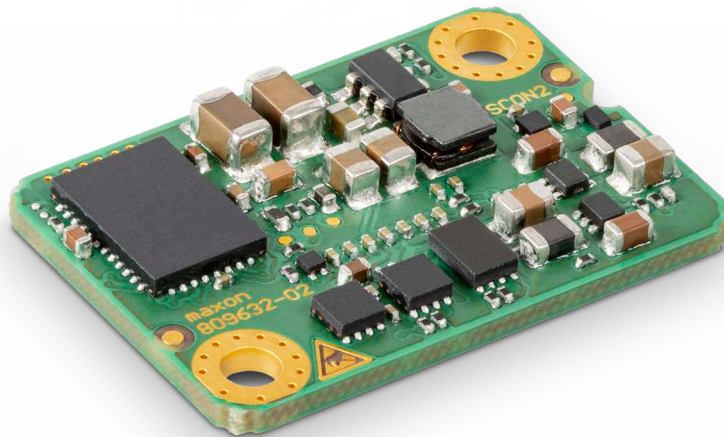

Servo Controller

# ESCON2 Nano 24/2

Hardware Reference



## TABLE OF CONTENTS

<b>1</b>	<b>ABOUT</b>	<b>5</b>
1.1	About this document . . . . .	5
1.2	About the device . . . . .	7
1.3	About the safety precautions . . . . .	8
<b>2</b>	<b>SPECIFICATIONS</b>	<b>9</b>
2.1	Technical data . . . . .	9
2.2	Thermal data . . . . .	10
2.2.1	Test setup for data collection . . . . .	10
2.2.2	Derating of output current (operation without additional heat sink) . . . . .	11
2.2.3	Operation with additional heatsink . . . . .	12
2.2.4	Thermal accessories . . . . .	12
2.2.5	Power dissipation and efficiency . . . . .	13
2.3	Limitations . . . . .	14
2.4	Dimensional drawing . . . . .	14
2.5	Standards . . . . .	15
<b>3</b>	<b>SETUP</b>	<b>17</b>
3.1	Generally applicable rules . . . . .	17
3.2	Pin assignment . . . . .	18
3.3	Connection specifications . . . . .	20
3.3.1	Power supply . . . . .	20
3.3.2	Output voltages . . . . .	21
3.3.3	Motor . . . . .	21
3.3.4	Sensor 1 Hall sensor . . . . .	22
3.3.5	Sensor 2 Encoder / I/Os . . . . .	23
3.3.6	Digital I/Os . . . . .	28
3.3.7	Analog I/Os . . . . .	31
3.3.8	Serial Communication Interface (SCI) / RS232 . . . . .	32

### READ THIS FIRST

**These instructions are for qualified technical personnel only. Before you start any work:**

- Read this manual carefully.
- Make sure that you understand this manual.
- Follow all instructions in this manual.

*The product is partly completed machinery according to EU Directive 2006/42/EC, Article 2, Clause (g). You must incorporate it into or assemble it with other machinery or other partly completed machinery or equipment.*

**You must not put the device into service unless all these conditions are met:**

- The complete machinery complies with all applicable requirements of EU Directive 2006/42/EC.
- The complete machinery fulfills all applicable health and safety requirements.
- All interfaces are implemented and comply with the requirements given in this manual.

3.3.9	CAN	33
3.3.10	USB	35
3.3.11	Motor temperature sensor (future release)	36
3.4	Status indicators	37
<b>4</b>	<b>MOTHERBOARD DESIGN GUIDE</b>	<b>39</b>
4.1	Connection accessory - ready-to-use Evaluation Board	39
4.2	Requirements for components of third-party suppliers	39
4.2.1	Terminal sockets	39
4.2.2	Power supply voltage	40
4.2.3	Motor chokes	41
4.2.4	USB interface	42
4.2.5	CAN interface	43
4.2.6	Serial Communication Interface (SCI) / RS232	44
4.2.7	RS422 line receiver for differential incremental encoder or high-speed I/O signals	45
4.2.8	RS422 transceiver for differential SSI, BiSS C or high-speed I/Os signals	46
4.2.9	Digital outputs load switch	46
4.2.10	LEDs for device status indication	47
4.2.11	Recommended components and manufacturers	47
4.3	Design guidelines	50
4.3.1	Ground	50
4.3.2	Layout	50
4.3.3	SMT footprint	51
<b>5</b>	<b>WIRING</b>	<b>53</b>
5.1	Possible combinations to connect a motor	53
5.2	Main wiring diagram	55
5.3	Cabling	56
5.4	Excerpts	57
5.4.1	Power supply	57
5.4.2	DC motor	57
5.4.3	EC (BLDC) motor	57
5.4.4	Sensor 1 Hall sensor	58
5.4.5	Sensor 2 Encoder / I/Os	58
5.4.6	Digital I/Os	59
5.4.7	Analog I/Os	59
5.4.8	SCI / RS232	60
5.4.9	CAN	60
5.4.10	USB	60
5.4.11	Motor temperature sensor (future release)	61
	<b>LIST OF FIGURES</b>	<b>63</b>
	<b>LIST OF TABLES</b>	<b>65</b>
	<b>INDEX</b>	<b>67</b>

**••page intentionally left blank••**

## 1 ABOUT

### 1.1 About this document

#### 1.1.1 Intended purpose

This document familiarizes you with the ESCON2 Nano 24/2 Servo Controller. It describes the tasks for safe and proper installation and commissioning. Follow the instructions:

- to avoid dangerous situations,
- to keep installation and/or commissioning time at a minimum,
- to increase reliability and service life of the described equipment.

This document is part of a documentation set. It includes performance data, specifications, standards information, connection details, pin assignments, and wiring examples. The overview below shows the documentation hierarchy and how its parts are related:

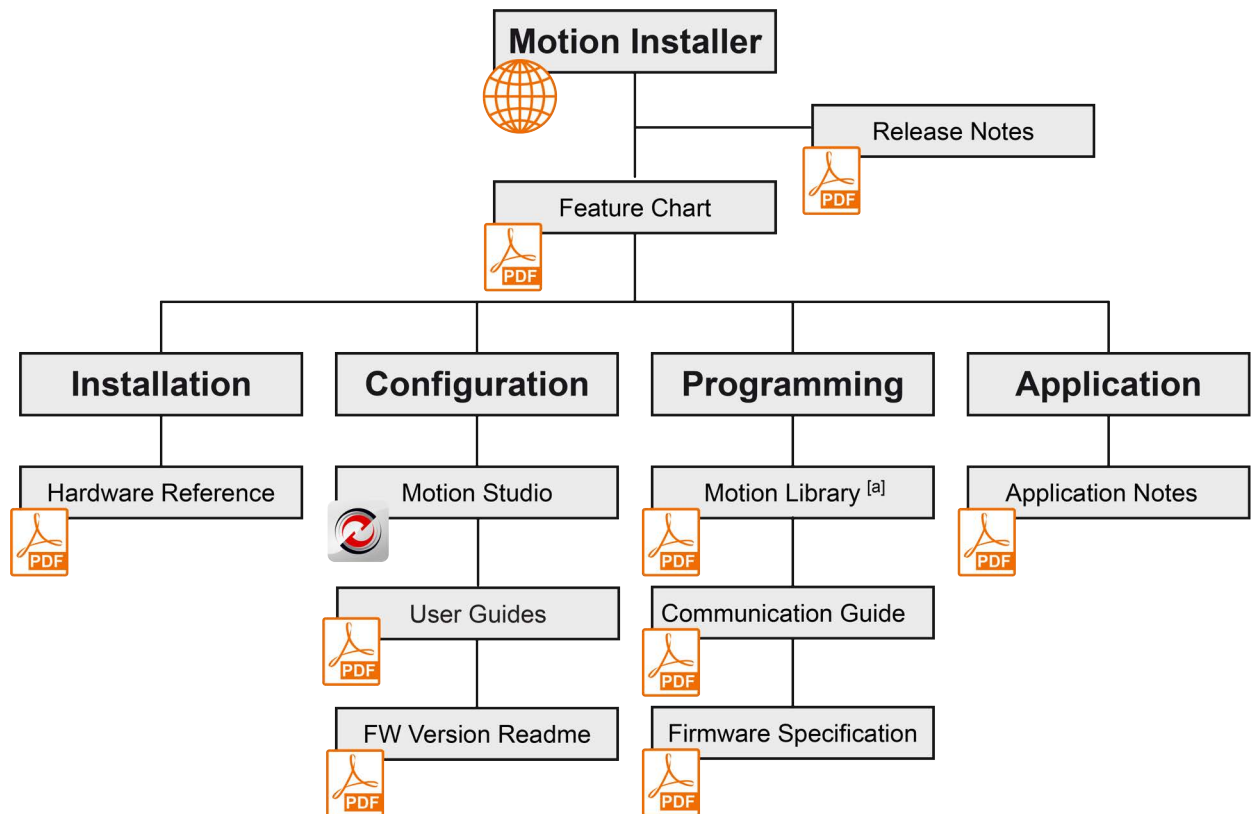

[a] including software programming examples

Figure 1-1 Documentation structure

Find the latest edition of this document, along with additional documentation and software for ESCON2 Servo Controllers, at: <http://escon.maxongroup.com>

#### 1.1.2 Target audience

This document is intended for trained and skilled personnel. It provides information on how to understand and perform the respective tasks and duties.

### 1.1.3 How to use

Follow these notations and codes throughout the document.

Notation	Meaning
ESCON2	stands for «ESCON2 Servo Controller»
«Abcd»	indicating a title or a name (such as of document, product, mode, etc.)
(n)	refers to an item (such as a part number, list items, etc.)
*	refers to an internal value
→	denotes “check”, “see”, “see also”, “take note of” or “go to”

Table 1-1 Notations used in this document

### 1.1.4 Symbols & signs

This document uses the following symbols and signs:

Type	Symbol	Meaning
<b>Safety alert DANGER</b>		Indicates an <b>imminent hazardous situation</b> . If not avoided, it <b>will result in death or serious injury</b> .
<b>WARNING</b>		Indicates a <b>potential hazardous situation</b> . If not avoided, it <b>can result in death or serious injury</b> .
<b>CAUTION</b>		Indicates a <b>probable hazardous situation</b> or calls the attention to unsafe practices. If not avoided, it <b>may result in injury</b> .
<b>Prohibited action</b>	 (typical)	Indicates a dangerous action. Hence, <b>you must not!</b>
<b>Mandatory action</b>	 (typical)	Indicates a mandatory action. Hence, <b>you must!</b>
<b>Requirement, Note, Remark</b>		Indicates an activity you must perform prior to continuing, or gives information on a particular point that must be observed.
<b>Best practice</b>		Indicates an advice or recommendation on the easiest and best way to further proceed.
<b>Material Damage</b>		Indicates information particular to possible damage of the equipment.

Table 1-2 Symbols and signs

### 1.1.5 Trademarks and brand names

All trademarks, brand names or other signs mentioned in this manual remain the property of their respective owners. They are protected by trademark, copyright, and/or other applicable laws. For easier reading, no symbols such as ® or ™ are being used with respect to the trademarks or brand names mentioned herein.

Nothing in this manual shall be construed as granting any rights with respect to the mentioned trademarks, brand named or other signs, including without limitation neither the right to use the mentioned trademarks, brand names or other signs without permission of the respective owners.

The trademarks, brand names or other signs are mentioned in this manual solely for information or identification purposes.

### 1.1.6 Copyright

© 2026 maxon. All rights reserved. Any use, in particular reproduction, editing, translation, and copying, without prior written approval is not permitted (contact: maxon international ltd., Brünigstrasse 220, CH-6072 Sachseln, +41 41 666 15 00, www.maxongroup.com). Infringements will be prosecuted under civil and criminal law. The mentioned trademarks belong to their respective owners and are protected under trademark laws. Subject to change without prior notice.

CCMC | ESCON2 Nano 24/2 Hardware Reference | Edition 2026-04 | DocID rel13591

### 1.1.7 Sources for additional information

For further details and additional information, please refer to the resources listed below:

Ref. no.	Reference
[1]	maxon: ESCON2 Communication Guide <a href="http://escon.maxongroup.com">http://escon.maxongroup.com</a>
[2]	maxon: ESCON2 Firmware Specification <a href="http://escon.maxongroup.com">http://escon.maxongroup.com</a>

Table 1-3 Sources for additional information

## 1.2 About the device

The ESCON2 Nano 24/2 is a small, powerful 4-quadrant PWM Servo Controller. Its high power density allows flexible use for brushed DC motors and brushless EC (BLDC) motors up to 48 Watts. It supports various feedback options, such as Hall sensors, incremental encoders, and absolute sensors for many drive applications.

The device is designed to be controlled by analog and digital set values, or as a slave node in a CANopen network. You can also operate it via any USB or RS232 communication port of a Windows workstation. It has extensive analog and digital I/O functions.

Latest technology, such as field-oriented control (FOC), acceleration and velocity feed forward, in combination with highest control cycle rates allow sophisticated, ease-of-use motion control.

The miniaturized OEM plug-in module integrates easily into complex applications. A suitable Evaluation Board, the ESCON2 EB Nano (P/N 834838), provides standard industry connector interfaces for commissioning and evaluation purposes.

You can find the latest edition of this document on the Internet: →<http://escon.maxongroup.com>. This website also gives you access to related documents and software for ESCON2 servo controllers.



In addition, you can watch video tutorials in the ESCON video library. These tutorials show how to start with «Motion Studio». They also show how to set up communication interfaces, configure the controller, and give helpful tips, etc. Explore the video library on Vimeo: →<https://vimeo.com/album/4646396>

### 1.3 About the safety precautions

- Read and understand the note → «READ THIS FIRST»!
- Do not start any work unless you have the required skills → Chapter “1.1.2 Target audience” on page 1-5.
- Refer to → Chapter “1.1.4 Symbols & signs” on page 1-6 to understand the symbols used.
- Follow all applicable health, safety, accident prevention, and environmental protection regulations for your country and work site.



#### **DANGER**

##### **High voltage and/or electrical shock**

**Touching live wires can cause death or serious injuries.**

- *Treat all power cables as live unless proven otherwise.*
- *Ensure neither end of the cable is connected to live power.*
- *Ensure the power source cannot be turned on while you work.*
- *Follow lock-out/tag-out procedures.*



#### **Requirements**

- *Install all devices and components according to local regulations.*
- *Electronic devices are not fail-safe. Install separate monitoring and safety equipment for each machine. If the machine has a failure, the drive system must go into a safe state and stay in this state. Possible failures include incorrect operation, failure of the control unit, failure of the cables, or other faults.*
- *Do not repair any components that maxon supplies.*



#### **Electrostatic sensitive device (ESD)**

- *Observe precautions for handling Electrostatic sensitive devices.*
- *Handle the device with care.*

## 2 SPECIFICATIONS

### 2.1 Technical data

ESCON2 Nano 24/2 (P/N 809635)		
Electrical data	Nominal power supply voltage $V_{CC}$	5...24 VDC 6...24 VDC (with use of sensor supply voltage output)
	Nominal logic supply voltage $V_C$	—
	Absolute supply voltage $V_{min} / V_{max}$	4.75 VDC / 28 VDC 5.8 VDC / 28 VDC (with use of sensor supply voltage output)
	Output voltage (max.)	$0.90 \times V_{CC}$
	Output current $I_{cont} / I_{max}$ (< 6.5 s)	2 A / 6 A (current measurement resolution: 5.37 mA)
	Pulse Width Modulation (PWM) frequency	50 kHz
	Sampling rate PI current controller	50 kHz
	Sampling rate PI speed controller	10 kHz
	Sampling rate analog input	50 kHz
	Max. efficiency	93 % → Figure 2-5
	Max. speed DC motor	Is limited by the max. permissible motor speed and the max. output voltage of the controller.
	Max. speed EC motor	120,000 rpm (FOC, 1 pole pair). Can be limited by the max. permissible motor speed and the max. output voltage of the controller.
	Built-in motor choke per phase	—
Inputs & outputs	Sensor 1 Digital Hall sensor H1, H2, H3	0...24 VDC (internal pull-up)
	Sensor 2 (choice between multiple functions):	
	• Digital incremental encoder	2-channel, single-ended, 0...12 VDC, max. 6.25 MHz
	• SSI absolute encoder	0.4...2 MHz (single-ended, configurable)
	• BiSS C unidirectional absolute encoder	0.4...4 MHz (single-ended, configurable)
	• High-speed digital inputs 1...2	Logic: 0...12 VDC, max. 6.25 MHz
	• High-speed digital inputs 3...4	Logic: 0...12 VDC, max. 6.25 MHz
	• High-speed digital output 1	3.3 VDC / $R_i = 270 \Omega$
Digital Inputs 1...4	Logic: 0...25 VDC, inputs 1...2 PWM capable	
Digital Outputs 1...2	3.3 VDC / $R_i = 270 \Omega$ , PWM capable	
Analog Inputs 1...2	Resolution 12-bit, 0...5 VDC (referenced to GND), 10 kHz	
Analog Outputs 1...2	Resolution 12-bit, 0...3.3 VDC (referenced to GND), 25 kHz	
Motor temperature sensor [a]	Resolution 12-bit, 0...3.3 VDC (internal pull-up)	
Voltage outputs	Sensor supply voltage $V_{Sensor}$	5 VDC / $I_L \leq 145$ mA
	Peripheral supply voltage $V_{Peripheral}$	3.3 VDC / $I_L \leq 20$ mA (unprotected)

Continued on next page.

ESCON2 Nano 24/2 (P/N 809635)			
<b>Motor connections</b>	DC motor	+ Motor, – Motor	
	EC motor	Motor winding 1, Motor winding 2, Motor winding 3	
<b>Communication interfaces</b>	CAN	Max. 1 Mbit/s, external transceiver required	
	RS232	Max. 115'200 bit/s, external transceiver required	
	USB	12 Mbit/s (Full Speed)	
<b>Status indicators</b>	Device status	external LEDs required	
<b>Mechanical data</b>	Dimensions (L × W × H)	23 × 16 × 4.5 mm	
	Weight (approx.)	2.5 g	
	Mounting	Pluggable (using header) and M2 screws	
<b>Environmental conditions</b>	Temperature	Operation	–40...+45 °C
		Extended range [b]	+45...+70 °C Derating: approx. –0.077 A/°C →Figure 2-2 with additional heatsink: →Figure 2-3
		Storage	–40...+85 °C
	Altitude [c]	Operation	0...500 m MSL
		Extended range [b]	500...10'000 m MSL Derating →Figure 2-2
	Humidity		5...90 % (condensation not permitted)

- [a] The functionality will be available with a future firmware release.
- [b] Operation within the extended range is permitted. However, a respective derating (declination of output current  $I_{cont}$ ) as to the stated values will apply.
- [c] Operating altitude in meters above Mean Sea Level, MSL.

Table 2-4 Technical data

## 2.2 Thermal data



### **Mandatory operation within the specified limits**

- Operation within the specified thermal limits is mandatory.
- If the ambient temperature exceeds the specified limits, thermal overload can occur even at low output currents.

### 2.2.1 Test setup for data collection

Unless otherwise specified, the thermal data has been obtained using the ESCON2 Nano 24/2 (P/N 809635) installed on the ESCON2 EB Nano (P/N 834838). For details, refer to →Chapter “4.1 Connection accessory - ready-to-use Evaluation Board” on page 4-39. The installation was performed using two screws to simulate mounting on a customer-specific motherboard. The assembly was oriented with the Evaluation Board connections facing upward and the Nano positioned at the bottom. It was placed on thermally poorly conductive supports, effectively floating in air.

2.2.2 Derating of output current (operation without additional heat sink)

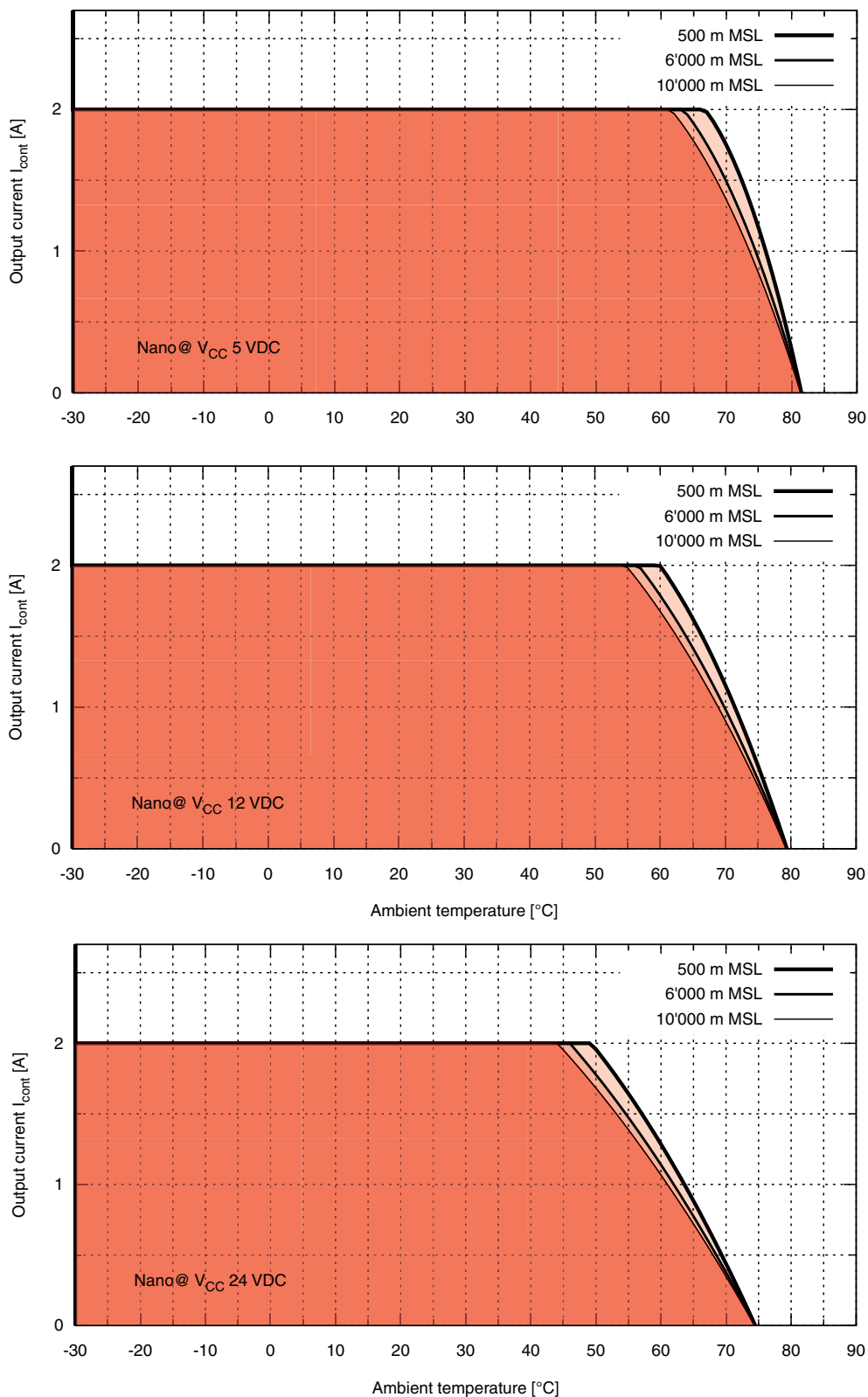

Figure 2-2 Derating of output current (operation without additional heatsink)

### 2.2.3 Operation with additional heatsink

During data collection in this chapter, the assembly was placed on its side. This position allows heat to flow upward from the additional heatsink, promoting effective passive cooling at the top.

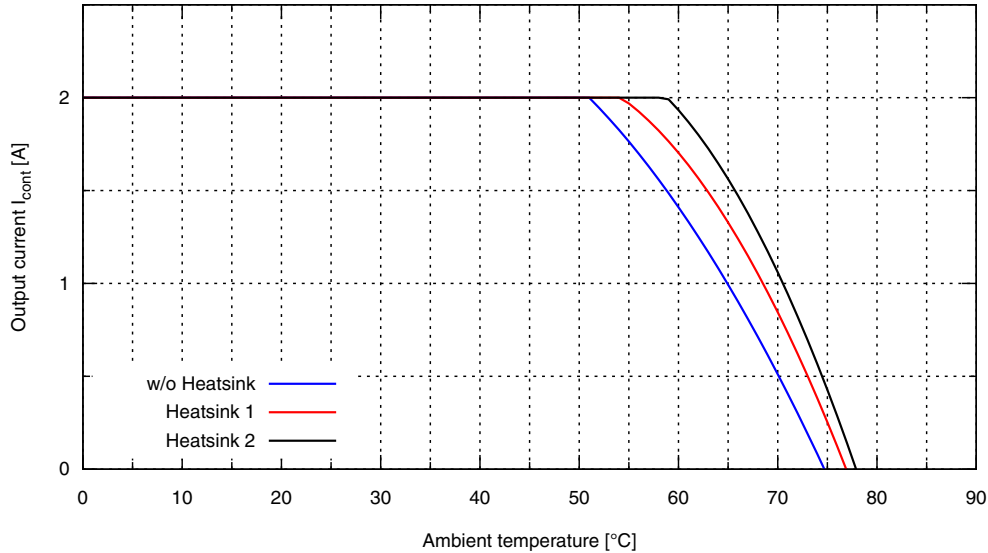

Figure 2-3 Extended operation @  $V_{CC}$  24 VDC with additional heatsink

Heatsink	Manufacturer	Type	Dimensions [mm]	Thermal resistance $R_{th}$ [K/W]
1	Fischer Elektronik GmbH	SK 631 25 SA	25 × 19 × 6	27.5
2	Fischer Elektronik GmbH	SK 633 25 SA	25 × 19 × 14	18

Table 2-5 Heatsink – tested components

### 2.2.4 Thermal accessories

maxon offers the ESCON2 Nano 24/2 Thermal Accessory Kit (P/N 876085), consisting of a thermal pad and a mounting frame. Both fit the ESCON2 Nano 24/2 perfectly.

Specifications		
ESCON2 Nano 24/2 Thermal Pad	Dimensions (L × W × H)	20 × 13 × 2.54 mm (with two cutouts at diagonally opposite corners of size 4.5 × 4.5 mm)
	Mounting	n/a (placed between controller and structure)
	Thermal conductivity	2.4 W/(mK)
ESCON2 Nano 24/2 Mounting Frame	Dimensions (L × W × H)	25.6 × 18.6 × 3.7 mm
	Mounting	2 holes ø2.2 mm

Table 2-6 Thermal accessories – specification

CAD files are available on the maxon website as part of the ESCON2 Nano 24/2 Thermal Accessory Kit (P/N 876085).

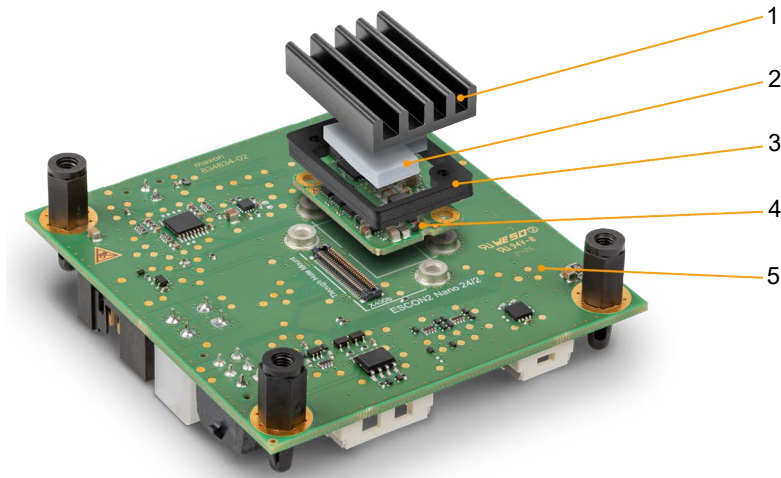

- |   |                |   |                  |
|---|----------------|---|------------------|
| 1 | Heatsink [a]   | 2 | Thermal Pad      |
| 3 | Mounting Frame | 4 | ESCON2 Nano 24/2 |
| 5 | ESCON2 EB Nano |   |                  |

[a] The heatsink is not part of the accessory kit and shown for illustration purposes only.

Figure 2-4 Assembly with thermal accessories

**2.2.5 Power dissipation and efficiency**

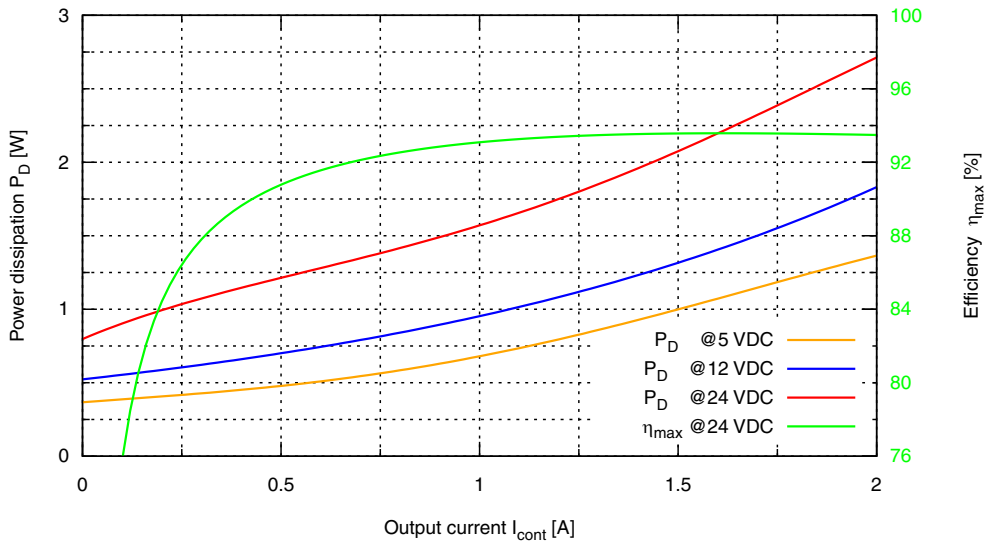

Figure 2-5 Power dissipation and efficiency

### 2.3 Limitations

Functionality		Switch-off threshold [a]	Recovery threshold [b]
Undervoltage		4.5 VDC	4.55 VDC
Overvoltage		31 VDC	29 VDC
Overcurrent		9 A	—
Thermal overload	logic	108 °C	98 °C
	power stage	90 °C	—

[a] The controller triggers the corresponding fault reaction. The controller changes to the disabled state. Refer to →ESCON2 Firmware Specification [2].

[b] The system allows you to reset the fault.

Table 2-7 Limitations

The device has a configurable output current limit and an overcurrent protection function. This protects the controller in case of a short circuit in a motor winding or a damaged power stage. The undervoltage, overvoltage, and thermal overload power stage protection limits are also configurable. For the thermal overload power stage protection, a linear derating of the maximum output current is implemented, which starts 10 °C below the switch-off threshold. For more information, see the →ESCON2 Firmware Specification [2].

### 2.4 Dimensional drawing

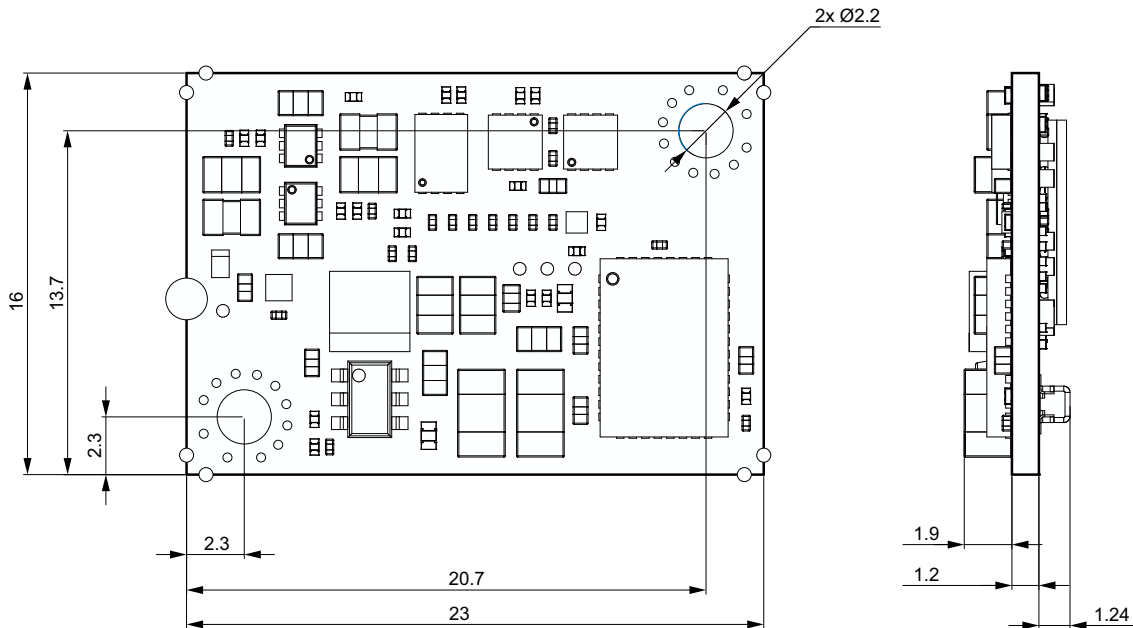

Figure 2-6 Dimensional drawing [mm]

## 2.5 Standards

The described device has been successfully tested for compliance with the standards listed below. Only the complete system (fully operational equipment with all components, such as the motor, servo controller, power supply unit, EMC filter, and cabling) can undergo an EMC test to ensure interference-free operation.



### Important notice

*Compliance of the device with the mentioned standards does not guarantee compliance in the final, ready-to-operate setup. To achieve compliance for your operational system, you must perform EMC testing on the complete equipment as a whole.*

Electromagnetic compatibility		
Generic	IEC/EN 61000-6-2	Immunity for industrial environments
	IEC/EN 61000-6-3	Emission standard for residential, commercial and light-industrial environments
Applied	IEC/EN 55022 (CISPR32)	Radio disturbance characteristics / radio interference
	IEC/EN 61000-4-3	Radiated, radio-frequency, electromagnetic field immunity test >10 V/m
	IEC/EN 61000-4-4	Electrical fast transient/burst immunity test ±2 kV
	IEC/EN 61000-4-6	Immunity to conducted disturbances, induced by radio-frequency fields 10 V <sub>rms</sub>

Others		
Environment	IEC/EN 60068-2-6	Environmental testing – Test Fc: Vibration (sinusoidal, 10...500 Hz, 20 m/s <sup>2</sup> )
	MIL-STD-810F	Random transport (10...500 Hz up to 2.53 g <sub>rms</sub> )
Safety	UL File Number	Unassembled printed circuit board: E207844
Reliability	MIL-HDBK-217F [a]	Reliability prediction of electronic equipment Environment: Ground, benign (GB) Ambient temperature: 298 K (25 °C) Component stress: In accordance with circuit diagram and nominal power Mean Time Between Failures (MTBF): 988'899 hours

[a] The reliability calculation is based on MIL-HDBK-217F. More accurate component manufacturer data has been used whenever possible.

Table 2-8 Standards

••page intentionally left blank••

## 3 SETUP

### IMPORTANT NOTICE: PREREQUISITES FOR INSTALLATION PERMISSION

The **ESCON2 Nano 24/2** is considered partly completed machinery according to EU Directive 2006/42/EC, Article 2, Clause (g). **It is intended to be incorporated into or assembled with other machinery or partly completed machinery or equipment.**



#### WARNING

##### **Risk of injury**

**Operating the device without full compliance of the surrounding system with EU Directive 2006/42/EC may cause serious injuries.**

- Do not operate the device unless you are certain that the other machinery fully complies with the EU directive's requirements.
- Do not operate the device, unless the other machinery fulfills all relevant health and safety aspects!
- Do not operate the device unless all respective interfaces have been established and fulfill the requirements stated in this document!



#### CAUTION

##### **Burn hazard**

**Hot surfaces can cause burns.**

- During operation, some parts of the device become very hot. Contact with these parts can burn your skin.
- Disconnect the power supply and secure it. Wait for the surface to cool before you do maintenance.

### 3.1 Generally applicable rules



#### **Maximum permitted supply voltage**

- Make sure that the power supply voltage is between 5...24 VDC, respectively 6...24 VDC if sensor supply voltage output is used.
- Supply voltages above 31 VDC or incorrect polarity will destroy the unit.
- The necessary output current depends on the load torque. The output current limits are:
  - continuous max. 2 A
  - short-time (acceleration) max. 6 A (< 6.5 s)



#### **Best practice**

Keep the motor mechanically disconnected during the setup and adjustment phase.

### 3.2 Pin assignment

For in-depth details on connections → Chapter “3.3 Connection specifications” on page 3-20.

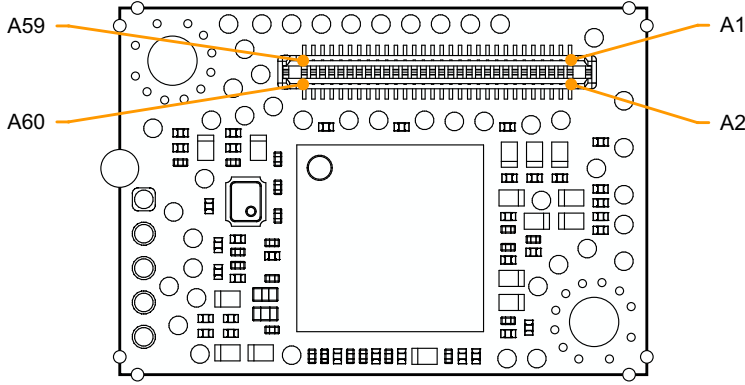

Figure 3-7 Pin assignment



#### Important notice

How to read the following data

The column «Pin» refers to the socket pin number.

For example: **A1...A3** means header A, pins 1 thru 3.

Pin	Signal	Description
A1, A2, A4 [a]	Motor winding 1	EC motor: Winding 1
	Motor (+M)	DC motor: Motor +
A3, A5, A6 [a]	Motor winding 2	EC motor: Winding 2
	Motor (-M)	DC motor: Motor -
A7, A8, A9 [a]	Motor winding 3	EC motor: Winding 3
	-	DC motor: DO NOT CONNECT
A10	GND	Ground
A11	GND	Ground
A12	-	For maxon internal use. DO NOT CONNECT
A13	Hall sensor 1	Hall sensor 1 input
A14	Channel A	Digital incremental encoder channel A
	HsDigIN1	High-speed digital input 1
A15	Hall sensor 2	Hall sensor 2 input
A16	Channel B	Digital incremental encoder channel B
	HsDigIN2	High-speed digital input 2
A17	Hall sensor 3	Hall sensor 3 input
A18	HsDigIN3	High-speed digital input 3
A19	LED red	LED red (warning/error) signal
A20	Data	Data (SSI, BiSS C)
	HsDigIN4	High-speed digital input 4
A21	LED green	LED green (operation) signal
A22	Clock	Clock (SSI, BiSS C)
	HsDigOUT1	High-speed digital output 1

Continued on next page.

Pin	Signal	Description
A23	DigIN1	Digital input 1
A24	V <sub>Sensor</sub>	Sensor supply voltage output (5 VDC / I <sub>L</sub> ≤ 145 mA)
A25	DigIN2	Digital input 2
A26	AnIN1	Analog input 1
A27	DigIN3	Digital input 3
A28	AnIN2	Analog input 2
A29	DigIN4	Digital input 4
A30	AnOUT1	Analog output 1
A31	DigOUT1	Digital output 1
A32	AnOUT2	Analog output 2
A33	DigOUT2	Digital output 2
A34	–	For maxon internal use. DO NOT CONNECT
A35	Auto bit rate	Automatic bit rate detection of CAN bus
A36	–	For maxon internal use. DO NOT CONNECT
A37	ID 1	CAN ID 1 (valence = 1)
A38	–	For maxon internal use. DO NOT CONNECT
A39	ID 2	CAN ID 2 (valence = 2)
A40	V <sub>Peripheral</sub>	Peripheral components supply voltage output (3.3 VDC / I <sub>L</sub> ≤ 20 mA; unprotected)
A41	ID 3	CAN ID 3 (valence = 4)
A42	MotorTemp	Motor temperature sensor input
A43	ID 4	CAN ID 4 (valence = 8)
A44	V <sub>Bus</sub>	USB supply voltage input (5 VDC)
A45	ID 5	CAN ID 5 (valence = 16)
A46	USB_D+	USB Data+ (twisted pair with USB Data–)
A47	ID 6	CAN ID 6 (valence = 32)
A48	USB_D–	USB Data– (twisted pair with USB Data+)
A49	GND	Ground
A50	GND	Ground
A51	CAN_TX	CAN communication interface transmit
A52	DSP_TxD	Serial communication interface transmit (UART)
A53	CAN_RX	CAN communication interface receive
A54	DSP_RxD	Serial communication interface receive (UART)
A55	GND	Ground
A56	V <sub>CC</sub>	Power supply voltage input (5...24 VDC / 6...24 VDC with use of V <sub>Sensor</sub> )
A57	GND	Ground
A58	V <sub>CC</sub>	Power supply voltage input (5...24 VDC / 6...24 VDC with use of V <sub>Sensor</sub> )
A59	GND	Ground
A60	V <sub>CC</sub>	Power supply voltage input (5...24 VDC / 6...24 VDC with use of V <sub>Sensor</sub> )

[a] Connect all pins in respect to the individual pin current rating.

Table 3-9 Pin assignment A1...A60

### 3.3 Connection specifications

The actual connection depends on your drive system configuration and the type of motor you are using. Follow the description in the given order and choose the wiring diagram (→see Page 5-55) that best suits your components.



**Important notice**

*How to read the following data*

*The column «Pin» refers to the socket pin number.  
For example: **A1...A3** means header A, pins 1 thru 3.*

#### 3.3.1 Power supply

Pin	Signal	Description
A55, A57, A59 [a]	GND	Ground
A56, A58, A60 [a]	V <sub>CC</sub>	Power supply voltage input (5...24 VDC / 6...24 VDC with use of V <sub>Sensor</sub> )

[a] Connect all pins in respect to the individual pin current rating.

Table 3-10 Power supply – Pin assignment

Power supply requirements	
Nominal output voltage V <sub>CC</sub>	5...24 VDC 6...24 VDC (with use of sensor supply voltage output)
Absolute output voltage V <sub>CC</sub>	min. 4.75 VDC / max. 28 VDC min. 5.8 VDC / max. 28 VDC (with use of sensor supply voltage output)
Output current	Depending on load • continuous max. 2 A • short-time (acceleration) max. 6 A (< 6.5 s)

Table 3-11 Power supply requirements

- 1) Use the formula below to calculate the required voltage under load.
- 2) Choose a power supply according to the calculated voltage. Consider the following:
  - a) During braking of the load, the power supply must buffer the recovered kinetic energy (e.g., in a capacitor).
  - b) If using an electronically stabilized power supply, ensure the overcurrent protection circuit is inoperative within the operating range.



**The formula already takes the following into account:**

- Maximum PWM duty cycle of 90 %
- Controller's max. voltage drop of 1 V @ 2 A

**KNOWN VALUES:**

- Operating torque M [mNm]
- Operating speed n [rpm]
- Nominal motor voltage U<sub>N</sub> [Volt]
- Motor no-load speed at U<sub>N</sub>; n<sub>O</sub> [rpm]
- Speed/torque gradient of the motor Δn/ΔM [rpm/mNm]

**SOUGHT VALUE:**

- Supply voltage V<sub>CC</sub> [Volt]

**SOLUTION:**

$$V_{CC} \geq \left[ \frac{U_N}{n_O} \cdot \left( n + \frac{\Delta n}{\Delta M} \cdot M \right) \cdot \frac{1}{0.90} \right] + 1[V]$$

**3.3.2 Output voltages**

Two output voltages are provided for the supply of external devices or as input voltage for I/Os. Typically:

- The sensor supply voltage ( $V_{\text{Sensor}}$ ) is used for Hall sensors, encoders, high-speed digital inputs, digital I/Os, or an external RS232 transceiver.
- The peripheral supply voltage ( $V_{\text{Peripheral}}$ ) is used for an external RS422 transceiver or other external devices.

Pin	Signal	Description
A10	GND	Ground
A24	$V_{\text{Sensor}}$	Sensor supply voltage output (5 VDC / $I_L \leq 145$ mA)
A40	$V_{\text{Peripheral}}$	Peripheral components supply voltage output (3.3 VDC / $I_L \leq 20$ mA; unprotected)
A49	GND	Ground

Table 3-12 Output voltages – Pin assignment



**Unprotected voltage output  $V_{\text{Peripheral}}$**

The peripheral supply voltage output ( $V_{\text{Peripheral}}$ ) is unprotected. Avoid any signals on this interface, as they can cause damage.

**3.3.3 Motor**

The controller is set to drive either an EC motor (BLDC, brushless DC motor) or a DC motor (brushed DC motor).



**Best practice**

Keep the motor mechanically disconnected during the setup and adjustment phase.

Pin	Signal	Description
A1, A2, A4 [a]	Motor winding 1	Winding 1
A3, A5, A6 [a]	Motor winding 2	Winding 2
A7, A8, A9 [a]	Motor winding 3	Winding 3

[a] Connect all pins in respect to the individual pin current rating.

Table 3-13 EC motor – Pin assignment

Pin	Signal	Description
A1, A2, A4 [a]	Motor (+M)	Motor +
A3, A5, A6 [a]	Motor (-M)	Motor -
A7, A8, A9 [a]	-	DC motor: DO NOT CONNECT

[a] Connect all pins in respect to the individual pin current rating.

Table 3-14 DC motor – Pin assignment

### 3.3.4 Sensor 1 Hall sensor

Pin	Signal	Description
A11	GND	Ground
A13	Hall sensor 1	Hall sensor 1 input
A15	Hall sensor 2	Hall sensor 2 input
A17	Hall sensor 3	Hall sensor 3 input
A24	V <sub>Sensor</sub>	Sensor supply voltage output (5 VDC / I <sub>L</sub> ≤ 145 mA)

Table 3-15 Hall sensor – Pin assignment



#### Important notice

The maximum supply current of the sensor supply voltage output V<sub>Sensor</sub> is in total 145 mA. It can be used for:

- Hall sensors → Chapter “3.3.4 Sensor 1 Hall sensor” on page 3-22
- Incremental encoders → Chapter “3.3.5.1 Incremental encoder” on page 3-23
- SSI / BiSS C encoders → Chapter “3.3.5.2 SSI / BiSS C unidirectional absolute encoder” on page 3-24
- Other peripherals which need a 5 VDC supply.

All currents resulting from parts connected to the sensor supply voltage output V<sub>Sensor</sub> must not exceed 145 mA in total.

Hall sensor	
Sensor supply voltage output V <sub>Sensor</sub>	5 VDC
Max. Hall sensor supply current	145 mA (→ refer to Important notice)
Input voltage	0...24 VDC
Max. input voltage	24 VDC
Low-level input voltage	< 0.8 VDC
High-level input voltage	> 2.0 VDC
Internal pull-up resistor	2.7 kΩ (referenced to 5 VDC - 0.6 VDC)

Table 3-16 Hall sensor specification

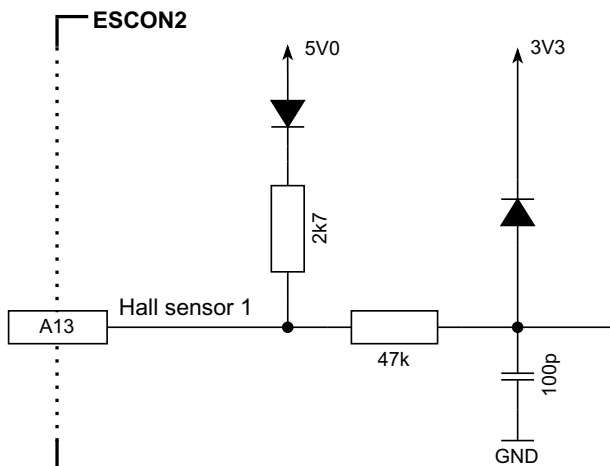

Figure 3-8 Hall sensor 1 input circuit (analogously valid for Hall sensors 2 & 3)

**3.3.5 Sensor 2 Encoder / I/Os**

You can connect additional sensors, either incremental encoders, serial encoders, or digital inputs and outputs. Only one sensor or function can be used at a time: either an incremental encoder, an absolute encoder, or high-speed digital I/Os.

**3.3.5.1 Incremental encoder**



**Best practice**

For best performance and resistance against electrical interference, **use encoders with a line driver (differential scheme)**. Otherwise, limitations may apply due to slow switching edges. The controller supports only a single-ended (unsymmetrical) scheme, but guidance is provided in → Chapter “4.2.7 RS422 line receiver for differential incremental encoder or high-speed I/O signals” on page 4-45 to implement a differential receiver on the motherboard.

Pin	Signal	Description
A10	GND	Ground
A14	Channel A	Digital incremental encoder channel A
A16	Channel B	Digital incremental encoder channel B
A24	V <sub>Sensor</sub>	Sensor supply voltage output (5 VDC / I <sub>L</sub> ≤ 145 mA)

Table 3-17 Incremental encoder – Pin assignment



**Important notice**

The maximum supply current of the sensor supply voltage output V<sub>Sensor</sub> is in total 145 mA. It can be used for:

- Hall sensors →Chapter “3.3.4 Sensor 1 Hall sensor” on page 3-22
- Incremental encoders →Chapter “3.3.5.1 Incremental encoder” on page 3-23
- SSI / BiSS C encoders →Chapter “3.3.5.2 SSI / BiSS C unidirectional absolute encoder” on page 3-24
- Other peripherals which need a 5 VDC supply.

All currents resulting from parts connected to the sensor supply voltage output V<sub>Sensor</sub> must not exceed 145 mA in total.

Digital incremental encoder (single-ended)		
Sensor supply voltage output V <sub>Sensor</sub>	5 VDC	
Max. sensor supply current	≤ 145 mA (→refer to Important notice)	
Input voltage	0...5 VDC	
Max. input voltage	± 12 VDC	
Low-level input voltage	< 1 VDC	
High-level input voltage	> 2.4 VDC	
Input high current	I <sub>IH</sub> = typically 0.33 mA @ 5 VDC	
Input low current	I <sub>IL</sub> = typically 0 mA @ 0 VDC	
Max. input frequency	Push-pull	6.25 MHz
	Open collector	100 kHz (required external 3k3 pull-up)

Table 3-18 Single-ended digital incremental encoder specification

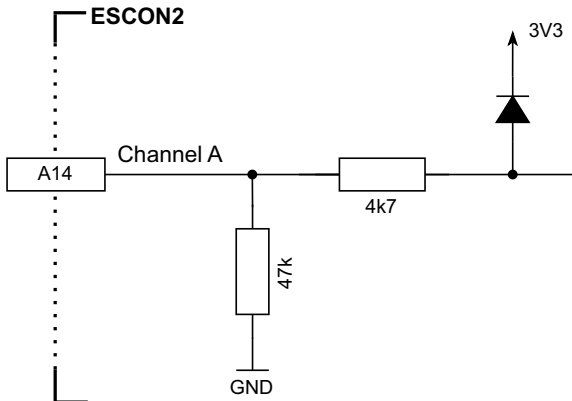

Figure 3-9 Digital incremental encoder input circuit Ch A “single-ended” (analogously valid for Ch B)

### 3.3.5.2 SSI / BiSS C unidirectional absolute encoder



#### Best practice

For cable lengths over 30 cm and for best performance and resistance against electrical interference, **use encoders with a line driver (differential scheme)**. This requires an external transceiver on the motherboard (see → Chapter “4.2.8 RS422 transceiver for differential SSI, BiSS C or high-speed I/Os signals” on page 4-46).

Pin	Signal	Description
A10	GND	Ground
A20	Data	Data (SSI, BiSS C)
A22	Clock	Clock (SSI, BiSS C)
A24	$V_{Sensor}$	Sensor supply voltage output (5 VDC / $I_L \leq 145$ mA)

Table 3-19 SSI / BiSS C unidirectional absolute encoder – Pin assignment



#### Important notice

The maximum supply current of the sensor supply voltage output  $V_{Sensor}$  is in total 145 mA. It can be used for:

- Hall sensors → Chapter “3.3.4 Sensor 1 Hall sensor” on page 3-22
- Incremental encoders → Chapter “3.3.5.1 Incremental encoder” on page 3-23
- SSI / BiSS C encoders → Chapter “3.3.5.2 SSI / BiSS C unidirectional absolute encoder” on page 3-24
- Other peripherals which need a 5 VDC supply.

All currents resulting from parts connected to the sensor supply voltage output  $V_{Sensor}$  must not exceed 145 mA in total.

SSI / BiSS C unidirectional absolute encoder (single-ended)		
Sensor supply voltage output $V_{Sensor}$	5 VDC	
Max. sensor supply current	$\leq 145$ mA (→ refer to Important notice)	
Clock frequency	SSI	0.4...2 MHz
	BiSS C	0.4...4 MHz

Table 3-20 SSI / BiSS C unidirectional absolute encoder specification

The maximum clock frequency (data rate) depends on the encoder cable length and the encoder configuration. For more information, for example configurable clock frequencies (data rates), refer to the → ESCON2 Firmware Specification [2].

SSI / BiSS C unidirectional absolute encoder data channel	
Input voltage	0...5 VDC
Max. input voltage	± 12 VDC
Low-level input voltage	< 1.0 VDC
High-level input voltage	> 2.4 VDC
Input high current	$I_{IH}$ = typically 0.33 mA @ 5 VDC (→refer to Important notice)
Input low current	$I_{IL}$ = typically 0 mA @ 0 VDC (→refer to Important notice)
Max. input frequency	6.25 MHz
Total reaction time	< 1.5 ms

Table 3-21 Single-ended SSI / BiSS C unidirectional absolute encoder data channel specification

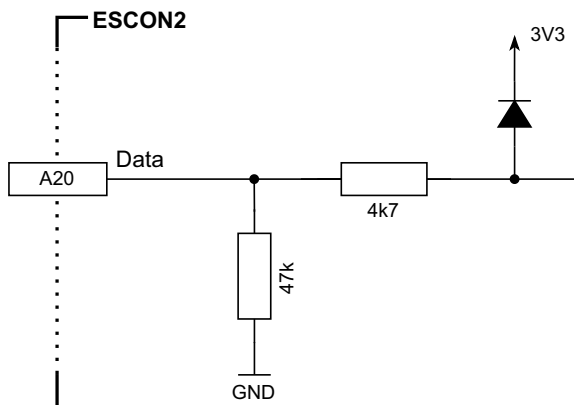

Figure 3-10 SSI absolute encoder data input (analogously valid for BiSS C)

SSI / BiSS C unidirectional absolute encoder clock channel		
Output voltage		3.3 VDC
Output resistance	Total	270 Ω (220 Ω + 50 Ω)
	Processor internal	50 Ω
Clock frequency	SSI	0.4...2 MHz
	BiSS C	0.4...4 MHz

Table 3-22 Single-ended SSI / BiSS C unidirectional absolute encoder clock channel specification

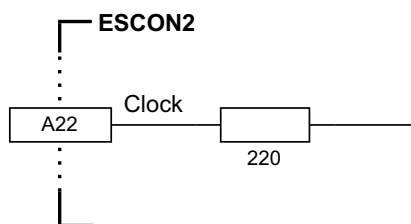

Figure 3-11 SSI absolute encoder clock output (analogously valid for BiSS C)

### 3.3.5.3 High-speed digital I/Os

Alternatively, the sensor interface can be used for high-speed digital I/O operation.

Pin	Signal	Description
A10	GND	Ground
A14	HsDigIN1	High-speed digital input 1
A16	HsDigIN2	High-speed digital input 2
A18	HsDigIN3	High-speed digital input 3
A20	HsDigIN4	High-speed digital input 4
A22	HsDigOUT1	High-speed digital output 1
A24	V <sub>Sensor</sub>	Sensor supply voltage output (5 VDC / I <sub>L</sub> ≤ 145 mA)

Table 3-23 High-speed digital I/Os – Pin assignment

High-speed digital inputs 1...4 (single-ended)	
Input voltage	0...5 VDC
Max. input voltage	± 12 VDC
Low-level input voltage	< 1.0 VDC
High-level input voltage	> 2.4 VDC
Input high current	HsDigIN1...4 I <sub>IH</sub> = typically 0.33 mA @ 5 VDC
Input low current	HsDigIN1...4 I <sub>IL</sub> = typically 0 mA @ 0 VDC
Max. input frequency	6.25 MHz
Total reaction time	< 1.5 ms

Table 3-24 Single-ended high-speed digital input specification

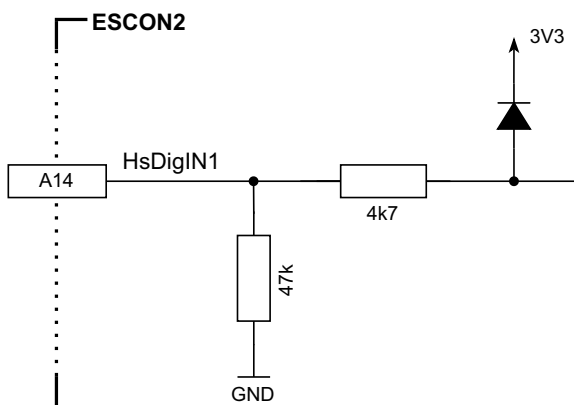

Figure 3-12 HsDigIN1 circuit “single-ended” (analogously valid for HsDigIN2...4)

**WIRING EXAMPLES**

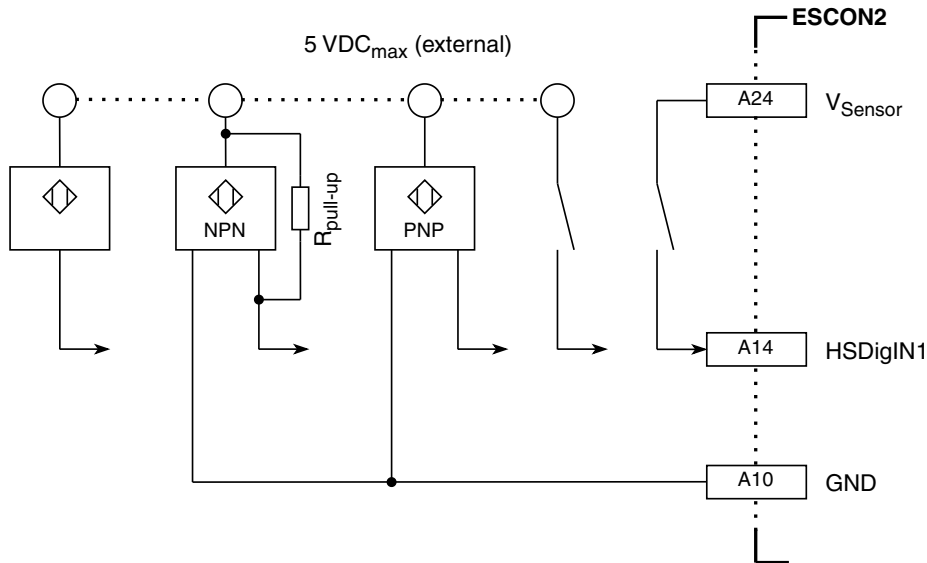

Figure 3-13 Wiring examples for proximity sensors and switches on HsDigIN1 (analogously valid for HsDigIN2..4)

High-speed digital output 1		
Output voltage	3.3 VDC	
Output resistance	Total	270 Ω (220 Ω + 50 Ω)
	Processor internal	50 Ω
Max. output frequency	25 kHz	

Table 3-25 High-speed digital output specification

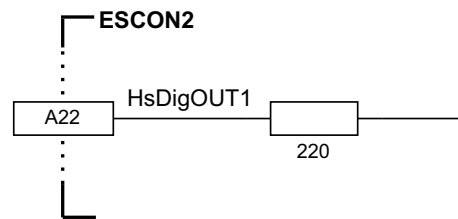

Figure 3-14 HsDigOUT1 circuit

**WIRING EXAMPLES**

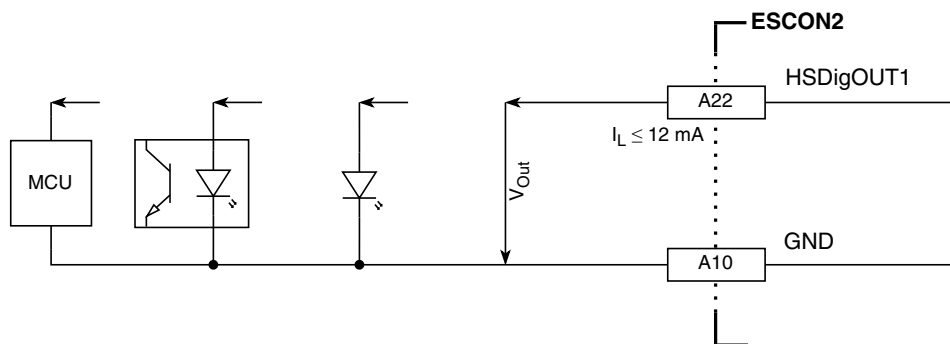

Figure 3-15 Wiring examples for "sourcing" on HsDigOUT1

### 3.3.6 Digital I/Os

Pin	Signal	Description
A11	GND	Ground
A23	DigIN1	Digital input 1
A24	V <sub>Sensor</sub>	Sensor supply voltage output (5 VDC / I <sub>L</sub> ≤ 145 mA)
A25	DigIN2	Digital input 2
A27	DigIN3	Digital input 3
A29	DigIN4	Digital input 4
A31	DigOUT1	Digital output 1
A33	DigOUT2	Digital output 2

Table 3-26 Digital I/Os – Pin assignment

Digital inputs 1...2	
Input voltage	0...25 VDC
Max. input voltage	± 25 VDC
Low-level input voltage	< 0.8 VDC
High-level input voltage	> 2.1 VDC
Input resistance	typically 47 kΩ < 3.3 VDC typically 37 kΩ @ 5 VDC typically 25 kΩ @ 24 VDC
Input current at logic 1	typically 135 μA @ 5 VDC
Hardware switching delay	< 6 μs
Total reaction time	< 2.3 ms
PWM duty cycle (resolution)	10...90 % (0.1 %)
PWM frequency	50 Hz...10 kHz
PWM accuracy	typically +0.1 % absolute @ 50 Hz / 5 VDC typically +1.5 % absolute @ 10 kHz / 5 VDC

Table 3-27 Digital inputs 1...2 specification

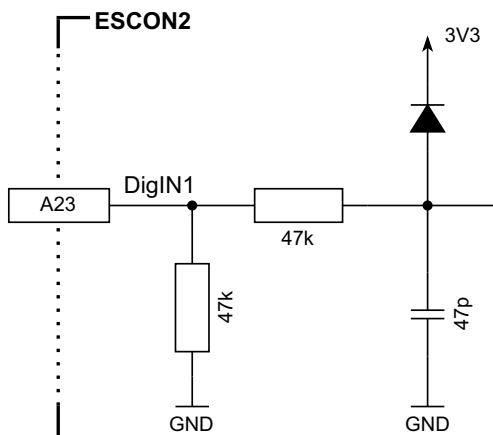

Figure 3-16 DigIN1 circuit (analogously valid for DigIN2)

Digital inputs 3...4	
Input voltage	0...25 VDC
Max. input voltage	± 25 VDC
Low-level input voltage	< 0.8 VDC
High-level input voltage	> 2.1 VDC
Input resistance	typically 47 kΩ < 3.3 VDC typically 37 kΩ @ 5 VDC typically 25 kΩ @ 24 VDC
Input current at logic 1	typically 135 μA @ 5 VDC
Hardware switching delay	< 300 μs
Total reaction time	< 2.3 ms

Table 3-28 Digital inputs 3...4 specification

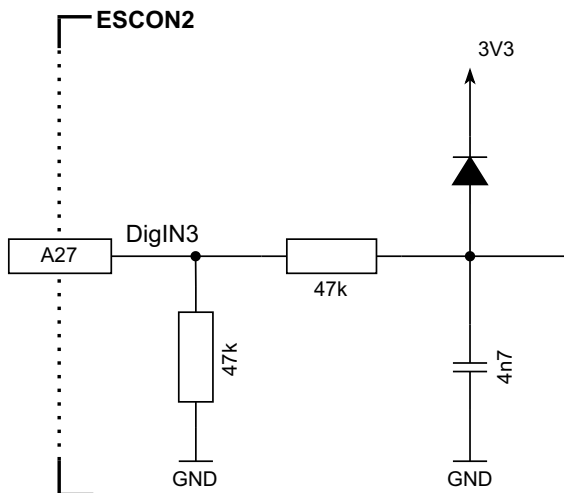

Figure 3-17 DigIN3 circuit (analogously valid for DigIN4)

## WIRING EXAMPLES

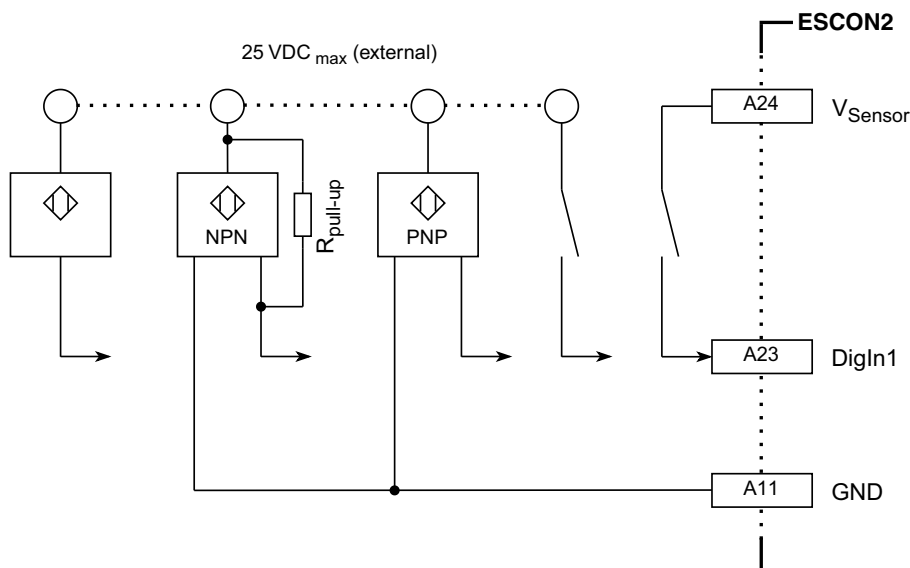

Figure 3-18 Wiring examples for proximity sensors and switches on DigIN1 (analogously valid for DigIN2..4)

Digital outputs 1...2		
Output voltage	3.3 VDC	
Output resistance	Total	270 $\Omega$ (220 $\Omega$ + 50 $\Omega$ )
	Processor internal	50 $\Omega$
Max. output frequency	25 kHz	

Table 3-29 Digital output specification

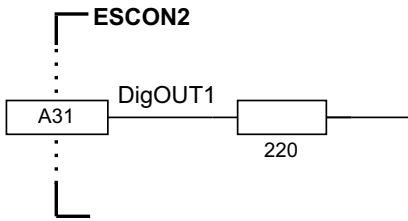

Figure 3-19 DigOUT1 circuit (analogously valid for DigOUT2)

For connecting devices that require a larger output current, use an external load switch on the motherboard (see → Chapter “4.2.9 Digital outputs load switch” on page 4-46).

**WIRING EXAMPLES**

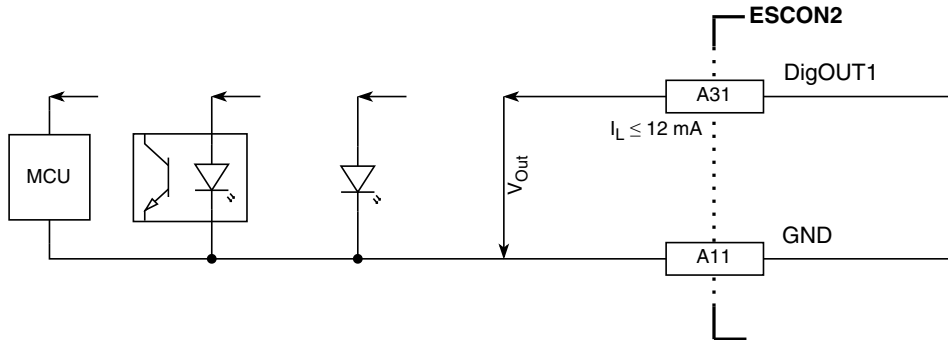

Figure 3-20 Wiring examples for "sourcing" on DigOUT1 (analogously valid for DigOUT2)

3.3.7 Analog I/Os

Pin	Signal	Description
A10	GND	Ground
A24	V <sub>Sensor</sub>	Sensor supply voltage output (5 VDC / I <sub>L</sub> ≤ 145 mA)
A26	AnIN1	Analog input 1
A28	AnIN2	Analog input 2
A30	AnOUT1	Analog output 1
A32	AnOUT2	Analog output 2
A42	MotorTemp	Motor temperature sensor input

Table 3-30 Analog I/O – Pin assignment

Analog inputs 1...2	
Input voltage	0...5 VDC
Max. input voltage	±10 VDC
Input resistance	5.9 kΩ
A/D converter	12-bit
Resolution	1.22 mV
Bandwidth	10 kHz

Table 3-31 Analog input specification

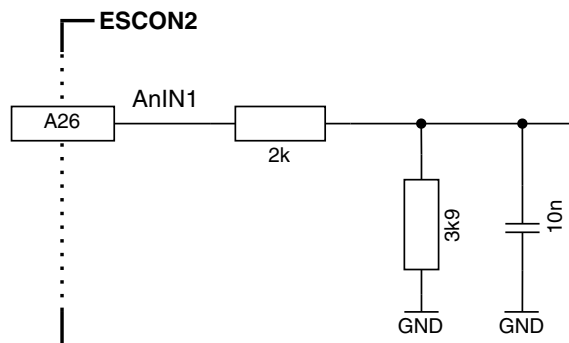

Figure 3-21 AnIN1 circuit (analogously valid for AnIN2)

WIRING EXAMPLES

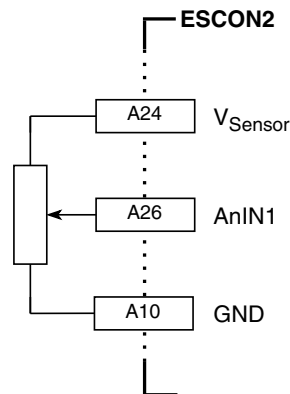

Figure 3-22 Wiring examples for a potentiometer on AnIN1 (analogously valid for AnIN2)

The figure above shows how to connect an external potentiometer to the analog input. It is recommended to use a potentiometer that has a resistance of 10 kΩ or more to reduce the load on the voltage output.

Analog outputs 1...2	
Output voltage	0...3.3 VDC
D/A converter	12-bit
Resolution	0.81 mV
Refresh rate	50 kHz
Analog bandwidth of output amplifier	25 kHz
Max. capacitive load	300 nF <b>Note:</b> The increase rate is limited in proportion to the capacitive load (e.g. 5 V/ms @ 300 nF)
Max. output current limit	1 mA

Table 3-32 Analog output specification

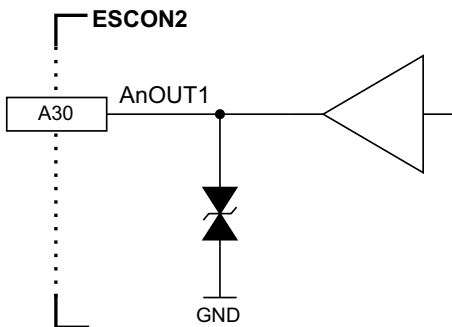

Figure 3-23 AnOUT1 circuit (analogously valid for AnOUT2)

### 3.3.8 Serial Communication Interface (SCI) / RS232

The SCI is a two-wire asynchronous serial port, commonly known as a UART. It supports digital communication between the CPU and other asynchronous peripherals that use the standard non-return-to-zero (NRZ) format.

A common use of the SCI is to build an RS232 interface by wiring it to an RS232 transceiver.



#### Bit rate setting

- Consider the master's maximal bit rate.
- The standard bit rate setting (factory setting) is 115'200 bit/s.

Pin	Signal	Description
A52	DSP_TxD	Serial communication interface transmit (UART)
A54	DSP_RxD	Serial communication interface receive (UART)

Table 3-33 SCI – Pin assignment

Serial Communication Interface (SCI)	
Input voltage	0...3.3 VDC
Max. input voltage	5 VDC
High-level input voltage	> 1.8 VDC
Low-level input voltage	< 1 VDC
High-level output voltage	> 2.4 VDC
Low-level output voltage	< 0.4 VDC
Series resistance transmit	–
Max. bit rate	115'200 bit/s
Data format	NRZ (non-return-to-zero)

Table 3-34 SCI specification

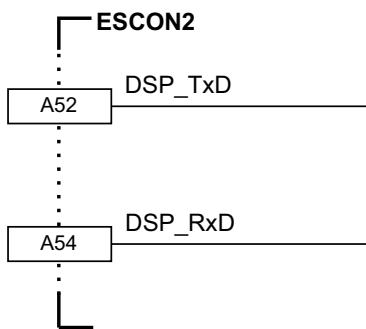

Figure 3-24 SCI circuit

### 3.3.9 CAN

#### 3.3.9.1 Interface

The ESCON2 is specially designed to be commanded and controlled via a Controller Area Network (CAN), a highly efficient data bus common in all fields of automation and motion control. It is preferably used as a slave node in the CANopen network. An external CAN transceiver is required on the motherboard (→ see Chapter “4.2.5 CAN interface” on page 4-43) to utilize the CAN interface.

Pin	Signal	Description
A49	GND	Ground
A51	CAN_TX	CAN communication interface transmit
A53	CAN_RX	CAN communication interface receive

Table 3-35 CAN – Pin assignment

CAN interface	
Standard	ISO 11898-1:2015 ISO 11898-2:2003 (with external CAN transceiver)
Max. bit rate	1 Mbit/s
Max. number of CAN nodes	63/127 (via hardware/software setting)
Protocol	CiA 301 version 4.2.0
Node-ID setting	By external wiring or software

Table 3-36 CAN interface specification



**Note**

- Consider the CAN master's maximal bit rate.
- The standard bit rate setting (factory setting) is 1 Mbit/s.
- Use 120 Ω termination resistor at both ends of the CAN bus.
- For detailed CAN information see separate document → ESCON2 Communication Guide [1].

**3.3.9.2 Configuration**

The device's identification (ID) can be set by hardware (external wiring) or software using binary code:

Pin	Signal	Description	Binary Code	Valence
A35	Auto bit rate	Automatic bit rate detection of CAN bus	-	-
A37	ID 1	CAN ID 1	2 <sup>0</sup>	1
A39	ID 2	CAN ID 2	2 <sup>1</sup>	2
A41	ID 3	CAN ID 3	2 <sup>2</sup>	4
A43	ID 4	CAN ID 4	2 <sup>3</sup>	8
A45	ID 5	CAN ID 5	2 <sup>4</sup>	16
A47	ID 6	CAN ID 6	2 <sup>5</sup>	32
A49	GND	Ground	-	-
A50	GND	Ground	-	-

Table 3-37 CAN Auto bit rate / ID – Pin assignment

CAN ID	
Logic 1	connected to GND
Logic 0	not connected

Table 3-38 CAN ID specification

The set ID can be calculated by adding the valences of all inputs connected externally to GND. Use the following table as a (non-concluding) guide:

CAN ID						ID
1	2	3	4	5	6	
0	0	0	0	0	0	–
1	0	0	0	0	0	1
0	1	0	0	0	0	2
0	0	1	0	0	0	4
1	0	1	0	0	0	5
0	0	0	1	0	0	8
0	0	0	0	1	0	16
0	0	0	0	0	1	32
1	1	1	1	1	1	63

0 = ID input line not connected      1 = ID input line externally connected to GND

Table 3-39 ID – Examples

### SETTING THE ID BY MEANS OF «MOTION STUDIO»

- The ID may be set by software (changing object 0x2000 «Node-ID», range 1...127).
- The ID set by software is valid if the ID is set to "0" (none of the ID input lines connected).

### CAN AUTOMATIC BIT RATE DETECTION

With this function, the CANopen interface can be put in a "listen only" mode. For further details see separate document →ESCON2 Firmware Specification [2]. Automatic bit rate detection is activated when the input line is externally connected to GND.

Bit rate detection	
Logic 1	connected to GND
Logic 0	not connected

Table 3-40 Bit rate detection specification

### 3.3.10 USB



#### **USB potential differences may cause hardware damage**

High potential differences of the two power supplies of controller and PC/Notebook can lead to damaged hardware.

- Avoid potential differences between the power supply of controller and PC/Notebook or, if possible, balance them.
- Always establish physical USB connection first before switching on the power supply of the controller.
- It is recommended to use a galvanic isolator to avoid potential differences.

*With a galvanic isolator, you can also connect the USB while the system is powered (hot-plugging).*

*One suitable device is the USB Isolator 33204 from Wiesemann & Theis GmbH.*

Pin	PC's USB Terminal	Signal	Description
A44	1	V <sub>BUS</sub>	USB supply voltage input 5 VDC
A46	3	USB_D+	USB Data+ (twisted pair with USB Data-)
A48	2	USB_D-	USB Data- (twisted pair with USB Data+)
A50	4	GND	USB Ground

Table 3-41 USB – Pin assignment

USB	
Data signaling rate	12 Mbit/s (Full speed)
Max. bus supply voltage V <sub>BUS</sub>	5.25 VDC
Max. DC data input voltage	-0.3...+3.8 VDC

Table 3-42 USB interface specification

### 3.3.11 Motor temperature sensor (future release)

The functionality will only be available with a future firmware release.

Pin	Signal	Description
A42	MotorTemp	Motor temperature sensor input
A50	GND	Ground

Table 3-43 Motor temperature sensor – Pin assignment

Motor temperature sensor input	
Input voltage	0...3.3 VDC
Max. input voltage	+24 VDC
A/D converter	12-bit
Internal pull-up resistor	3.3 kΩ (referenced to 3.3 VDC)

Table 3-44 Motor temperature sensor – specifications

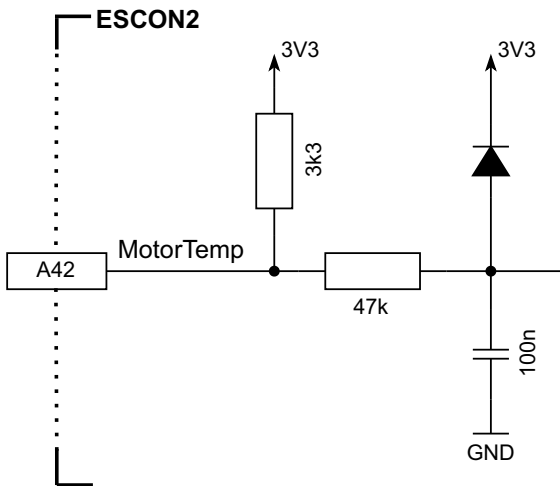

Figure 3-25 Motor temperature circuit

### 3.4 Status indicators

The ESCON2 Nano 24/2 provides two output signals to display the actual operation status and possible warnings and errors using LEDs. A set of green and red LEDs is recommended:

- Green LED shows the operation status
- Red LED indicates warnings and errors

LED		Warning / Error	Description
Green	Red		
Slow	OFF	No warning/error active.	Power stage is disabled. The ESCON2 is in status <ul style="list-style-type: none"> <li>• Switch on disabled</li> <li>• Ready to switch on</li> <li>• Switched on</li> </ul>
Slow	Slow	At least one warning is active.	
ON	OFF	No warning/error active.	Power stage is enabled. The ESCON2 is in status <ul style="list-style-type: none"> <li>• Operation enabled</li> <li>• Quick stop active</li> </ul>
ON	Slow	At least one warning is active.	
ON	ON	At least one error has occurred.	Power stage is enabled. The ESCON2 is in temporary status <ul style="list-style-type: none"> <li>• Fault reaction active</li> </ul>
OFF	ON	At least one error has occurred.	Power stage is disabled. The ESCON2 is in status <ul style="list-style-type: none"> <li>• Fault</li> </ul>
Flash	ON	n/a	Firmware update in progress or invalid application

Slow = LED is slowly blinking (0.5 s OFF, 0.5 s ON)  
Flash = LED is flashing (0.9 s OFF, 0.1 s ON)

Table 3-45 Device Status LEDs

Pin	Signal	Description
A19	LED red	LED red (warning/error) signal
A21	LED green	LED green (operation) signal

Table 3-46 Device status outputs - Pin assignment

Device status outputs	
Output voltage	3.3 VDC
Output resistance	50 Ω
Max. load current	5 mA

Table 3-47 Device status output specification

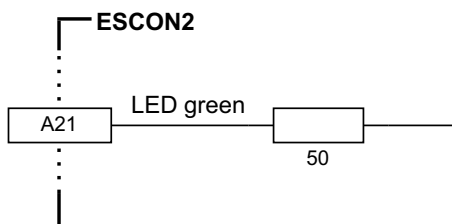

Figure 3-26 LED green circuit (analogously valid for LED red)

**••page intentionally left blank••**

## 4 MOTHERBOARD DESIGN GUIDE

The «Motherboard Design Guide» provides helpful information on integrating the Nano on a printed circuit board. It contains recommendations for the motherboard layout, specifies required external components, pin assignments, and provides connection examples.



### CAUTION

#### **Dangerous Action**

#### **Errors in implementing the design can result in serious Injury!**

- *Designing a printed circuit board requires special skills and knowledge and may only be performed by electronic developers!*
- *This quick guide is only intended as an aid. It does not claim to be complete and will not automatically result in a functional component.*



#### **Unused interfaces**

*If you do not use an interface, you may still need to connect the signals on the motherboard. For example, this can help prevent electrical noise. Read all sections of the motherboard design guide.*



#### **Get help**

*If you are not trained in the design and development of printed circuit boards, you will need additional support. maxon will be happy to provide you with a quote for designing and manufacturing a motherboard for your specific application.*

### 4.1 Connection accessory - ready-to-use Evaluation Board

The ESCON2 EB Nano (P/N 834838) is a ready-to-use Evaluation Board provided by maxon, specifically designed for seamless integration with the Nano. This Evaluation Board features industrial connectors compatible with maxon prefab cables, making it ideal for commissioning and evaluation purposes. For comprehensive details, refer to the hardware reference for the Evaluation Board (EB).

The guidelines in the following chapters are based on the design of this EB.

### 4.2 Requirements for components of third-party suppliers



#### **Best practice**

For references and recommended components consult → Table 4-48.

#### **4.2.1 Terminal sockets**

To implement a motherboard for the Nano, one terminal socket is required.

#### 4.2.2 Power supply voltage

To protect the Nano, it is recommended to use an external circuit breaker, a TVS diode, and a capacitor in the voltage supply circuit.

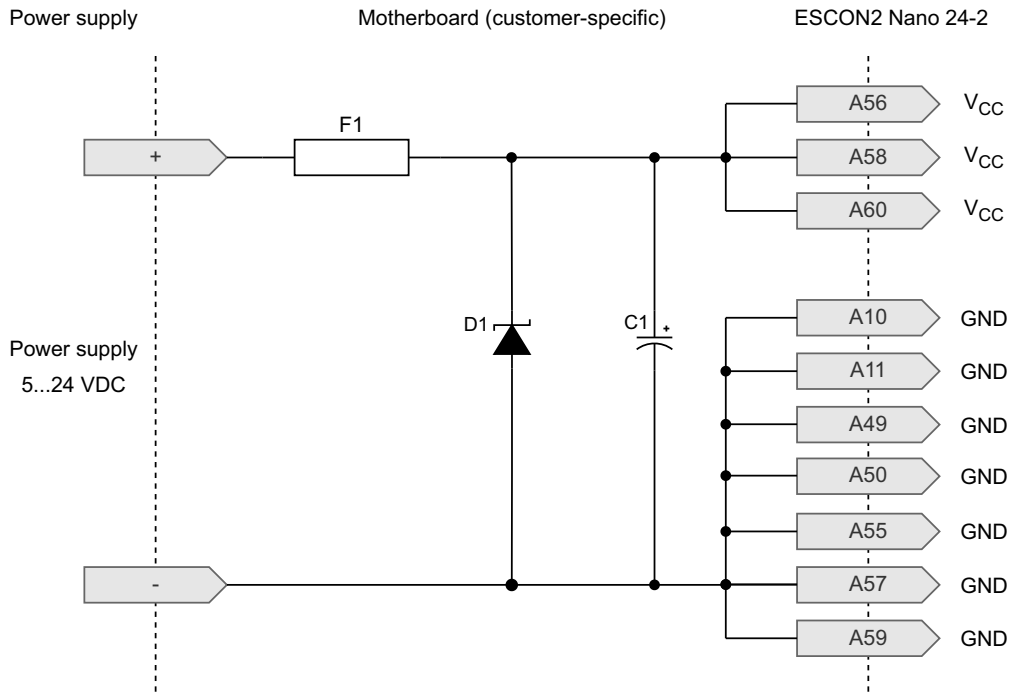

Figure 4-27 Wiring of power supply

##### Input Fuse (F1)

An input fuse (F1) is necessary in order to provide reverse polarity protection. Together with a unipolar TVS diode (D1), this prevents current from flowing in the wrong direction.

##### Capacitor (C1)

The Nano does not require an external capacitor for normal operation. Use an external capacitor to reduce voltage ripple and to buffer feedback currents, typically present during motor deceleration. Connect an electrolytic or ceramic capacitor (C1) to the supply voltage line. Placement of the capacitor close to the Nano can improve performance. This installation reduces oscillations caused by supply cable inductance or internal capacitors. These oscillations can cause a voltage overshoot during power plug-in.

##### TVS Diode (D1)

To protect against overvoltage resulting from voltage transients (short voltage spikes), we recommend connecting a TVS (transient voltage suppressor) diode (D1) to the voltage supply line.

### 4.2.3 Motor chokes

The Nano is not equipped with internal motor chokes.

Most motors and applications do not require additional chokes. However, in cases of high supply voltage with very low terminal inductance, the ripple of the motor current can reach an unacceptably high value. This can cause the motor to heat up unnecessarily and result in unstable control behavior. The minimum terminal inductance required per phase can be calculated using the following formula:

$$L_{Phase} \geq \frac{1}{2} \cdot \left( \frac{V_{CC}}{6 \cdot f_{PWM} \cdot I_N} - (0.3 \cdot L_{Motor}) \right)$$

$L_{Phase}[H]$	Additional external inductance per phase
$V_{CC}[V]$	Operating voltage $V_{CC}$
$f_{PWM}[Hz]$	Switching frequency of the power stage = 50'000 Hz
$I_N[A]$	Nominal current of the motor (→line 6 in the maxon catalog)
$L_{Motor}[H]$	Terminal inductance of the motor (→line 11 in the maxon catalog)

If the result of the calculation is negative, no additional chokes are necessary. However, using chokes with additional filter components can be beneficial for reducing electromagnetic interference emissions.

An additional choke must have electromagnetic shielding, an adequate saturation current, minimal losses, and a nominal current greater than the motor's continuous current. The wiring example below refers to an additional inductance of 33  $\mu$ H. If a different inductance is required, the filter components must also be adjusted accordingly. For further help with filter design, contact maxon Support at →<http://support.maxongroup.com>.

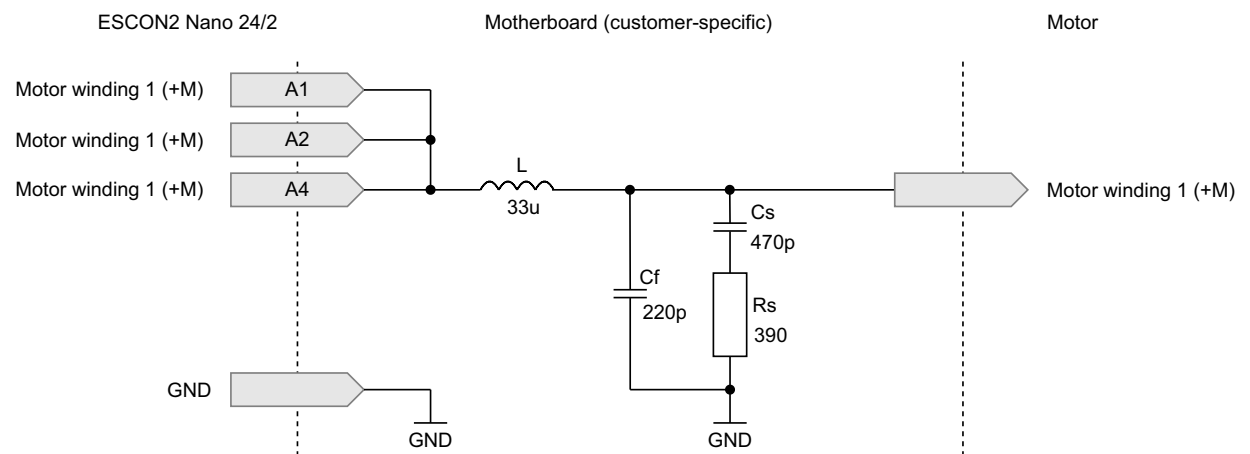

Figure 4-28 Wiring of motor winding 1 (analogously valid for motor winding 2 & 3)

#### 4.2.4 USB interface

Use of an USB-C connector is recommended. If the USB interface is used, integrate TVS diodes for protection against overvoltage transients.

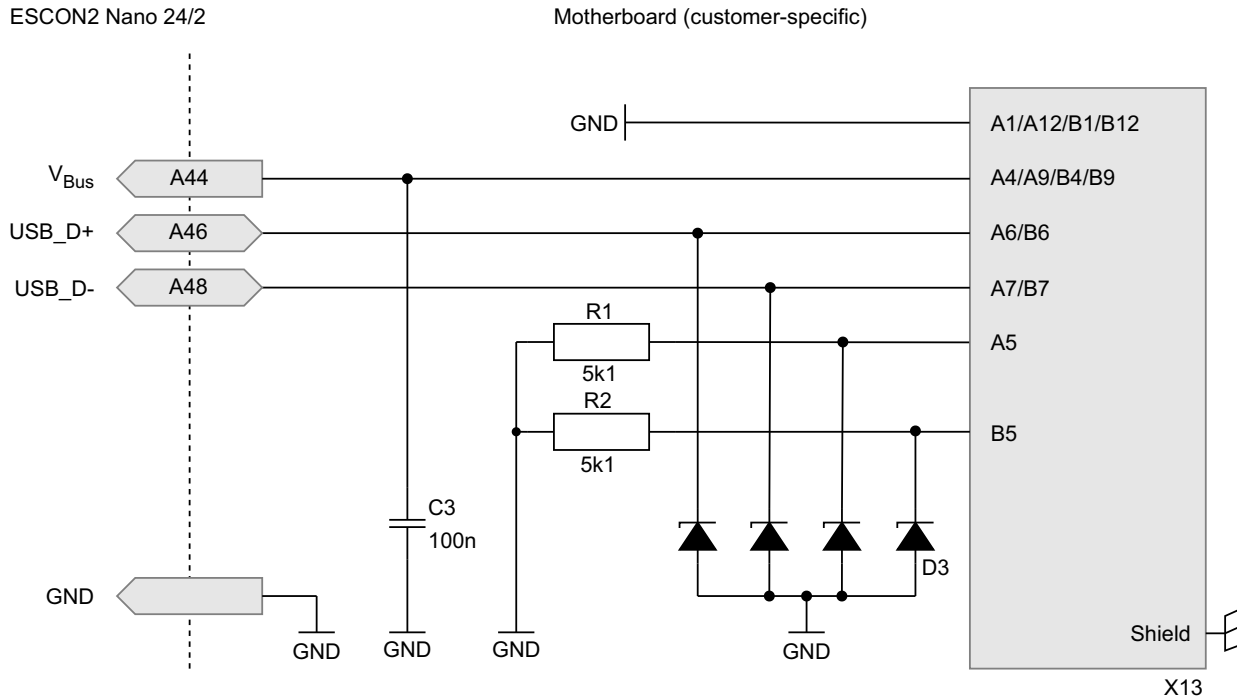

Figure 4-29 Wiring of USB-C connector

**4.2.5 CAN interface**

To use the CAN interface, install an external CAN transceiver (CAN driver/receiver). You must install a bus termination at both ends of the bus line.

The device's CAN ID (Node-ID) and automatic bit rate detection can be configured by hardware. To configure a given ID, connect CAN ID 1 through CAN ID 6 to GND as applicable (see →Chapter “3.3.9.2 Configuration” on page 3-34). To activate automatic bit rate detection, connect (A35) Auto bit rate to GND.

Alternatively, software settings can be used to adjust the parameters if the pins for automatic bit rate detection and CAN IDs are left open. If necessary, link the CAN high and the CAN low line to a 120 Ω bus termination resistor.

The following example shows a wiring with a CAN transceiver and CAN ID = 18, automatic bit rate detection activated and a 120 Ω bus termination resistor.

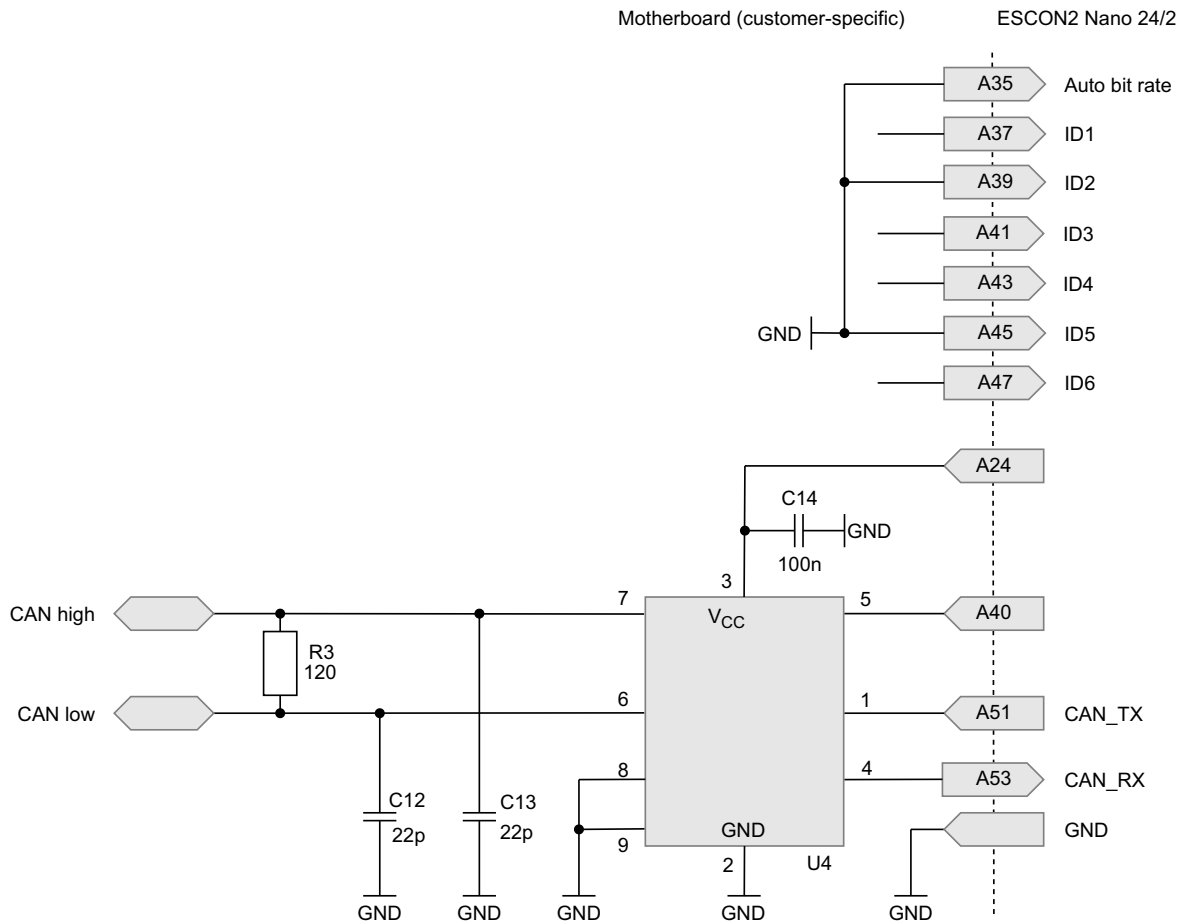

Figure 4-30 Wiring of CAN interface

If the CAN settings need to be variable, a DIP switch could be used, instead of fixed connections.

## 4.2.6 Serial Communication Interface (SCI) / RS232

### 4.2.6.1 Serial Communication Interface (SCI) not used

If the Serial Communication Interface (SCI) is not used and no transceiver is connected, connect the DSP\_RxD signal to a 100 nF capacitor. Connect the capacitor to ground (GND). This connection helps to avoid interference.

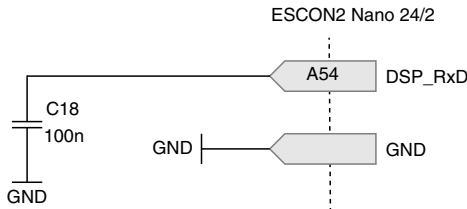

Figure 4-31 Wiring of Serial Communication Interface (SCI) not used

### 4.2.6.2 RS232 interface

To use the serial communication interface with an external RS232 master, an additional RS232 transceiver (line driver/receiver) is necessary on the motherboard. For board-level operation, the serial interface can be used for direct connection.

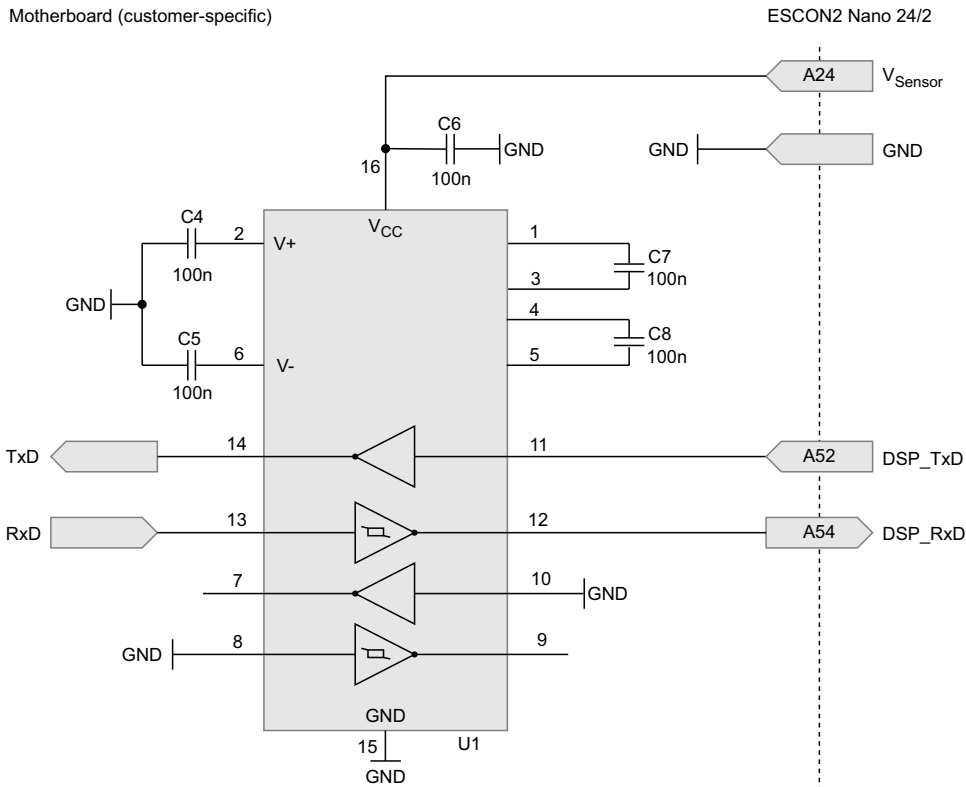

Figure 4-32 Wiring of RS232 interface



#### Important notice

If the Serial Communication Interface (SCI) is not used and no transceiver is connected, connect the DSP\_RxD signal to a 100 nF capacitor. Connect the capacitor to ground (GND). This connection helps to avoid interference.

**4.2.7 RS422 line receiver for differential incremental encoder or high-speed I/O signals**

Integrate an external RS422 line receiver on the motherboard to use a differential scheme for the incremental encoder or the high-speed digital inputs and outputs (I/Os).

The following example shows a wiring for encoder signals A and A\, and for high-speed digital input signals HsDigIN1 and HsDigIN1\. The wiring for the other signals is the same. You can copy this wiring for the other signals.

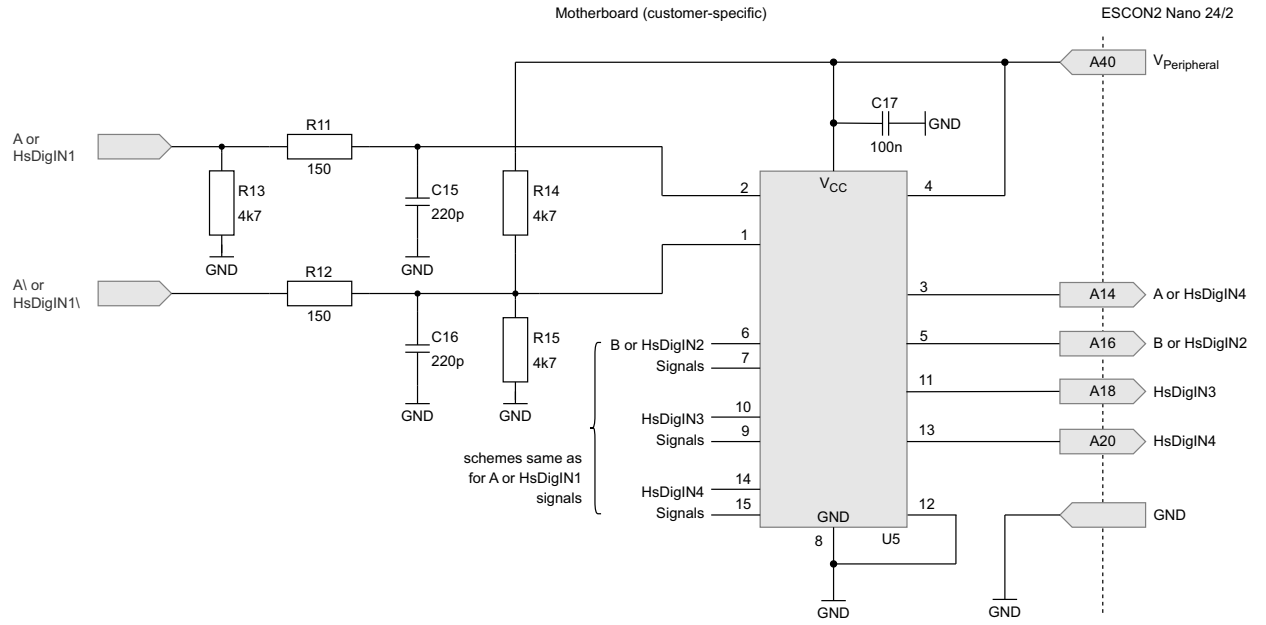

Figure 4-33 Wiring of RS422 line receiver for incremental encoder or high-speed I/O signals

#### 4.2.8 RS422 transceiver for differential SSI, BiSS C or high-speed I/Os signals

An external RS422 transceiver (line driver/receiver) is required for cable lengths over 30 cm or to utilize the SSI / BiSS C unidirectional absolute encoder or high-speed digital I/Os with differential signals. In the wiring example below, the TVS diodes act as safeguards against overvoltage transients.

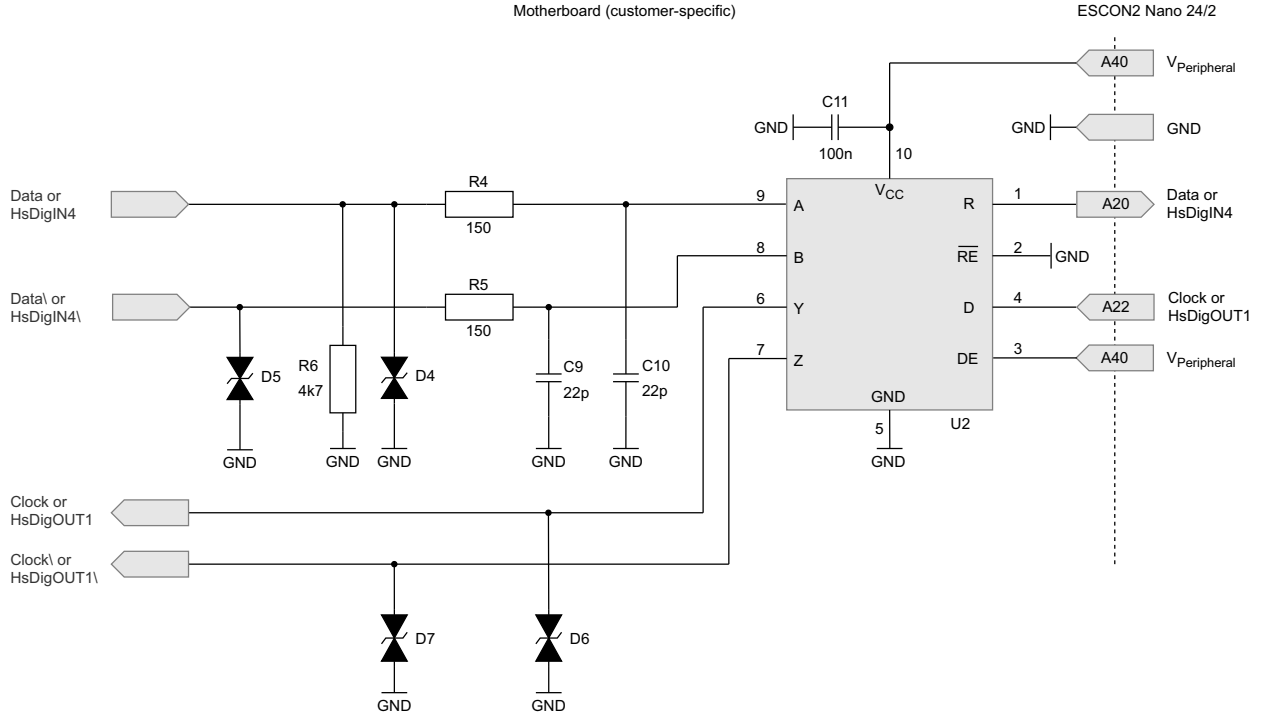

Figure 4-34 Wiring of RS422 transceiver

#### 4.2.9 Digital outputs load switch

The digital outputs can be equipped with a load switch to connect devices requiring a larger output current. In the given circuitry example, the external load must be supplied with a maximum voltage of 36 VDC, and the load current ( $I_L$ ) must not exceed 500 mA. This circuitry is not necessary if the digital output signals are only used for signal processing.

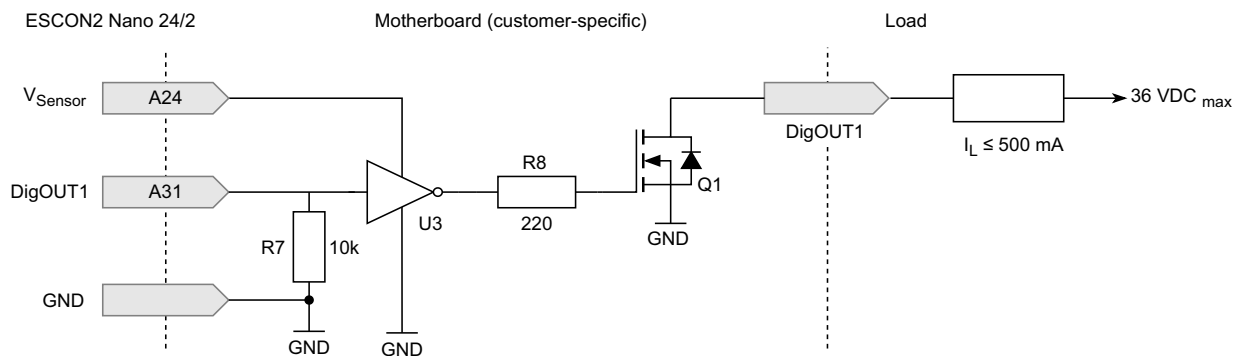

Figure 4-35 Wiring of digital output 1 load switch (analogously valid for digital output 2)



#### Freewheeling diode for inductive loads

When utilizing the digital output load switch for the operation of inductive loads, such as relays, it is essential to confirm the presence of a freewheeling diode to prevent potential harm to the hardware. If possible, install the freewheeling diode at the load.

**4.2.10 LEDs for device status indication**

A set of green and red LEDs can be integrated on the motherboard to indicate the device status. The green LED should be used for the operation status, and the red LED should be used for indicating warnings and errors. For further information, refer to → Chapter “3.4 Status indicators” on page 3-37.

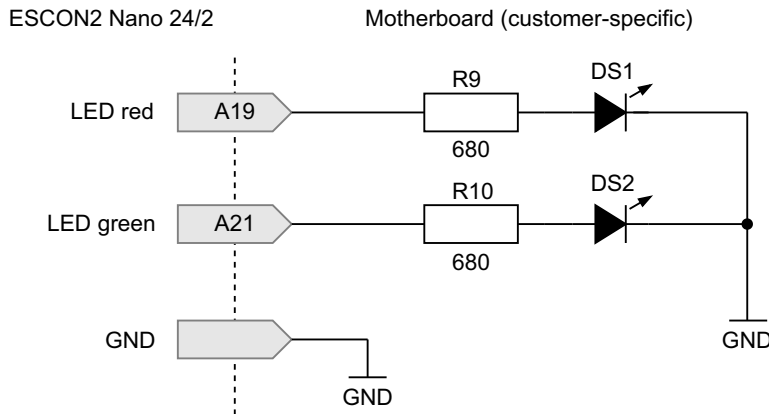

Figure 4-36 Wiring of LEDs for device status indication

**4.2.11 Recommended components and manufacturers**

Recommended components	
<b>Socket</b>	
Terminal socket	<b>60 poles:</b> <ul style="list-style-type: none"> <li>• Panasonic AXF5G6012</li> <li>• maxon 946601</li> </ul>
<b>Power supply voltage</b>	
Fuse (F1)	<b>4 A, 3.152 A<sup>2</sup>s</b> <ul style="list-style-type: none"> <li>• Littelfuse 0157004.DR</li> </ul>
TVS diode (D1)	<b>V<sub>R</sub> 28 VDC, V<sub>C</sub> 45.4 VDC</b> <ul style="list-style-type: none"> <li>• SMF28A</li> </ul>
Capacitor (C1)	<p>The ripple current load for C1 depends on the motor’s operating point and the power supply output capacity. Under worst-case conditions, the ripple current may reach <math>I_{cont} / 2</math>. Use capacitors with a rated voltage according to your supply voltage (e.g. <math>\geq 50</math> VDC for 24 VDC supply) and adequate ripple current to avoid overheating or reducing the lifetime of the capacitors.</p> <p><b>Remark:</b> If there is an excessive amount of reversed energy (e.g., during deceleration of loads with high inertia or during downward vertical movement), you may need to add an additional capacitor with much higher capacity (e.g., up to 10,000...47,000 <math>\mu</math>F) and/or a brake chopper, such as the maxon DSR 50/5 (P/N 309687).</p> <p><b>Example 1 for C1 with 24 VDC supply voltage:</b>  <math>I_{peak} = 6</math> A, <math>I_{cont} = 2</math> A, ripple current = <math>I_{cont} / 2 = 1</math> A, minimum solution with ceramic capacitors:                      Voltage ripple is sufficiently low with internal capacitors                      1-2 x ceramic capacitors 1206 / 4.7 <math>\mu</math>F / 50 VDC are recommended, but not necessary</p> <ul style="list-style-type: none"> <li>• Murata GCM31CC71H475KA03</li> <li>• Taiyo Yuden UMJ316BC7475KLHTE</li> </ul>

Continued on next page.

**Recommended components**

Capacitor (C1)	<p><b>Example 2 for C1 with 5 VDC supply voltage:</b>  <math>I_{peak} = 6\text{ A}</math>, <math>I_{cont} = 2\text{ A}</math>, ripple current = <math>I_{cont} / 2 = 1\text{ A}</math>, minimum solution with ceramic capacitors:  Voltage ripple must be <math>&lt; 0.9 V_{pp}</math>  2 x ceramic capacitors 1210 / 47 <math>\mu\text{F}</math> / 10 VDC must be used to meet this criterion</p> <ul style="list-style-type: none"> <li>Taiyo Yuden MSASL32MSB7476MPNB25</li> <li>Murata GRJ32ER71A476ME11K</li> <li>Murata GRM32ER71A476KE15L</li> <li>Samsung CL32B476MPJNNNE</li> </ul> <p><b>Example 3 for C1 with 5...24 VDC supply voltage:</b>  <math>I_{peak} = 6\text{ A}</math>, <math>I_{cont} = 2\text{ A}</math>, ripple current = <math>I_{cont} / 2 = 1\text{ A}</math>, comfortable solution with low ESR electrolytic capacitor:  1 x capacitor with 47 <math>\mu\text{F}</math>, 50 VDC, 1'550 mA RMS</p> <ul style="list-style-type: none"> <li>Panasonic EEHZA1H470P</li> <li>KYOCERA APA0809470M050R</li> <li>UCC HHXF500ARA470MHA0G</li> </ul> <p>Choosing capacitors with a rated ripple current higher than required will improve the component's lifetime.</p>
<b>Motor filter</b>	
Motor choke (L)	<p><b>33 <math>\mu\text{H}</math>, rated current <math>I_{RMS} \geq I_{cont} / I_{sat} \geq I_{peak}</math>, construction shielded</b></p> <ul style="list-style-type: none"> <li>Eaton SDCHA1V8040-330-R</li> <li>Bourns SRN8040TA-330M</li> </ul>
Filter capacitor ( $C_F$ )	<b>220 pF, 100 VDC</b>
Snubber resistor ( $R_S$ )	<b>390 <math>\Omega</math>, 1 %, 0.1 W</b>
Snubber capacitor ( $C_S$ )	<b>470 pF, 100 VDC</b>
<b>USB interface</b>	
USB connector (X13)	<p><b>USB Type C, vertical</b></p> <ul style="list-style-type: none"> <li>ASSMANN WSW AUSB1-DFN-HSR4</li> <li>Global Connector Technology USB4115-03-C</li> <li>Würth Elektronik 632722110112</li> </ul>
Resistor (R1, R2)	<b>5.1 k<math>\Omega</math>, 1 %, 0.0625 W</b>
Capacitor (C3)	<b>100 nF, 50 VDC</b>
TVS diode (D3)	<p><b>Quadruple ESD protection diode, <math>V_R</math> 5 VDC, <math>V_C</math> 10 VDC</b></p> <ul style="list-style-type: none"> <li>Nexperia PESD5V0L4UG</li> <li>onsemi NSQA6V8AW5T2G</li> <li>Toshiba DF5A6.8LFU</li> </ul>
<b>CAN interface</b>	
Transceiver (U4)	<p><b>High-speed CAN transceiver</b></p> <ul style="list-style-type: none"> <li>Nexperia TJA1051TK/3</li> <li>Texas Instruments TCAN1051GV-Q1</li> <li>Microchip MCP2542FD</li> </ul>
Resistor (R3)	<b>120 <math>\Omega</math>, 1 %, 0.125 W</b>
Capacitor (C12, C13)	<b>22 pF, 50 VDC</b>
Capacitor (C14)	<b>100 nF, 16 VDC</b>

Continued on next page.

Recommended components	
<b>Serial Communication Interface (SCI) not used</b>	
Capacitor (C18)	<b>100 nF, 16 VDC</b>
<b>RS232 interface</b>	
Transceiver (U1)	<b>Dual line driver and receiver with ESD protection</b> <ul style="list-style-type: none"> <li>• Texas Instruments MAX202IPW</li> <li>• ST Microelectronics ST202EBTR</li> </ul>
Capacitor (C4...C8)	<b>100 nF, 16 VDC</b>
<b>Differential incremental encoder or high-speed I/O signals</b>	
Receiver (U5)	<b>High-speed quadruple line receiver with ESD protection</b> <ul style="list-style-type: none"> <li>• Texas Instruments AM26LV32E</li> <li>• Renesas ISL32273E</li> </ul>
Resistor (R11, R12)	<b>150 Ω, 1 %, 0.0625 W</b>
Resistor (R13...R15)	<b>4.7 kΩ, 5 %, 0.0625 W</b>
Capacitor (C15, C16)	<b>220 p, 50 VDC</b>
Capacitor (C17)	<b>100 nF, 16 VDC</b>
<b>Differential absolute encoder or high-speed I/O signals</b>	
Transceiver (U2)	<b>Full-duplex line driver and receiver with ESD protection</b> <ul style="list-style-type: none"> <li>• Texas Instruments THVD1452DGSR</li> <li>• Texas Instruments SN65HVD76DGSR</li> <li>• Texas Instruments SN65HVD1476DGSR</li> </ul>
Resistor (R4, R5)	<b>150 Ω, 1 %, 0.0625 W</b>
Resistor (R6)	<b>4.7 kΩ, 1 %, 0.0625 W</b>
Capacitor (C9, C10)	<b>22 pF, 50 VDC</b>
Capacitor (C11)	<b>100 nF, 16 VDC</b>
TVS diode (D4...D7)	<b>ESD protection diode, <math>V_R</math> 12 VDC, <math>V_C</math> 22 VDC</b> <ul style="list-style-type: none"> <li>• Comchip CPDQC12VE-HF</li> <li>• Diodes D12V0L1B2LP-7B</li> <li>• Littelfuse SPHV12-01ETG-C</li> </ul>
<b>Digital outputs load switch</b>	
Inverter (U3)	<b>Inverter gate</b> <ul style="list-style-type: none"> <li>• Diodes 74AHCT1G04SE-7</li> <li>• Nexperia 74AHCT1G04GW</li> <li>• Texas Instruments SN74AHCT1G04DCKR</li> </ul>
Transistor (Q1)	<b>Fully autoprotected power MOSFET (dual)</b> <ul style="list-style-type: none"> <li>• ST Microelectronics VNS1NV04DPTR-E</li> </ul>
Resistor (R7)	<b>10 kΩ, 1 %, 0.0625 W</b>
Resistor (R8)	<b>220 Ω, 1 %, 0.0625 W</b>

Continued on next page.

Recommended components		
<b>LEDs for device status indication</b>		
Resistor (R9, R10)	<b>680 Ω, 1 %, 0.0625 W</b>	
LED (DS1)	<b>LED red</b>	
	• Dialight	599-0010-007F
	• Vishay	TLMS1100-GS15
	• ROHM	SML-D15UWT86C
LED (DS2)	<b>LED green</b>	
	• Dialight	598-8070-107F
	• Vishay	TLMG1100-GS15
	• ROHM	SML-D15MWT86C

Table 4-48 Motherboard design guide – Recommended components

### 4.3 Design guidelines

The following instructions serve as an aid when designing an application-specific motherboard and ensure the correct and reliable integration of the Nano.

While designing a motherboard, consider the following characteristics:

- Pin assignment (→page 3-18)
- Technical data (→page 2-9) and dimensional drawing (→page 2-14)

#### 4.3.1 Ground

All ground connections (GND) should be internally connected to the Nano (equal potential). It is customary to equip the motherboard with a ground plane. You should connect all ground connections to the voltage supply ground via wide conductive tracks.

Pin	Signal	Description
A10, A11, A49, A50, A55, A57, A59	GND	Ground

Table 4-49 Motherboard design guide – Grounding

If an earth potential is in place or required, you should connect the ground plane to the earth potential via one or more capacitors and one resistor. It is recommended to use ceramic capacitors with 10 nF and a minimum of 100 VDC and a resistor with 2 MΩ.

#### 4.3.2 Layout

Guidelines for the layout of the motherboard:

- Connect terminal socket pins (A56), (A58), and (A60) for nominal power supply voltage ( $V_{CC}$ ) to the fuse via wide conductive tracks.
- Connect terminal socket pins (A10), (A11), (A49), (A50), (A55), (A57), and (A59) for GND (ground) to the operating voltage ground via wide conductive tracks.
- The width of the conductive tracks and the copper coating thickness of the conductors for supply voltage and motor depend on the current required in your application. A minimum track width of 2 mm (79 mil) and a minimum copper coating thickness of 35 μm are recommended. The track width can be achieved using multilayer designs with distributed tracks.

### 4.3.3 SMT footprint

The figure below shows the footprint on the motherboard for the recommended terminal header (see → Table 4-48 on page 4-50). This footprint can also be downloaded from the manufacturer's webpage. The hole pattern shown corresponds to that of the ESCON2 Nano 24/2.

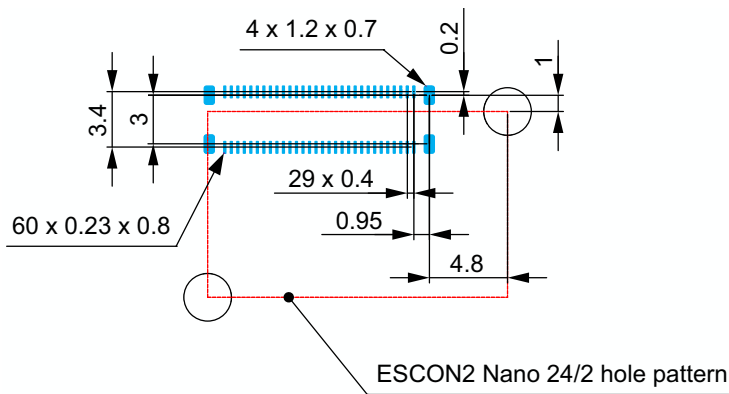

Figure 4-37 SMT footprint [mm] – Top view

### 4.3.4 Mounting of the Nano

The motherboard must support mounting the Nano using its two mounting holes, which are surrounded by GND circular rings. Utilize electrically and thermally conductive mounting materials to reduce the electrical load on the GND pins (see → Table 4-49 on page 4-50) and to enhance heat dissipation of the Nano. Ensure the mounting points on the motherboard establish a connection between the mounting parts and the motherboard's ground plane.

**••page intentionally left blank••**

## 5 WIRING

This section provides wiring information for your setup. You can either use the consolidated wiring diagrams (see →Figure 5-39) featuring the full scope of interconnectivity and pin assignments, or you may use the connection overviews for either DC motor or EC (BLDC) motor to determine the wiring for your particular motor type and the appropriate feedback signals.

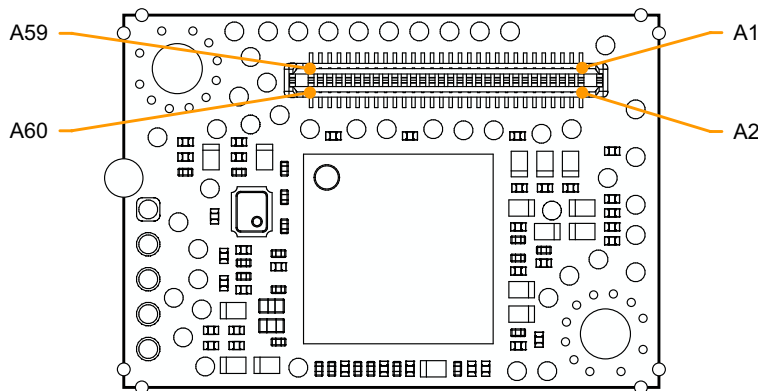



Figure 5-38 Interfaces – Designations and location



### Signs and abbreviations used

The subsequent diagrams feature these signs and abbreviations:

- «EC motor» stands for brushless EC motor (BLDC).
-  Ground safety earth connection (optional).

### 5.1 Possible combinations to connect a motor

The following tables show feasible ways to connect the motor with its respective feedback signals or possible combinations thereof. To find the wiring that best suits your setup, proceed as follows:

- 1) Decide on the type of motor you are using and go to the respective subsection;  
For DC motor, see →Chapter “5.1.1 DC motor” on page 5-54 or  
For EC (BLDC) motor, see →Chapter “5.1.2 EC (BLDC) motor” on page 5-54.
- 2) Connect the power supply as shown in the referenced figure.
- 3) Check-out the listing for the combination that best suits your setup. Pick the wiring method number and go to the respective table;  
For DC motor, see →Table 5-50,  
For EC (BLDC) motor see →Table 5-51.
- 4) Pick the row with the corresponding wiring method number and refer to the listed figure(s) to find the relevant wiring information.

**5.1.1 DC motor**

**Power supply**

Power supply .....Figure 5-40

**Motor & feedback signals**

Without sensor ..... Method # DC1 [a]

Digital incremental encoder ..... Method # DC2

SSI / BiSS C unidirectional absolute encoder ..... Method # DC3

Method #	Sensor 2		→Figure(s)
	Digital incremental encoder	SSI / BiSS C unidirectional absolute encoder	
DC1 [a]			5-41
DC2	✓		5-41 5-44
DC3		✓	5-41 5-45

[a] For method # DC1, only the operating mode current control can be used.

Table 5-50 Possible combinations of feedback signals for DC motor

**5.1.2 EC (BLDC) motor**

**Power supply**

Power supply .....Figure 5-40

**Motor & feedback signals**

Hall sensors ..... Method # EC1

Hall sensors & Digital incremental encoder ..... Method # EC2

Hall sensors & SSI / BiSS C unidirectional absolute encoder ..... Method # EC3

SSI / BiSS C unidirectional absolute encoder ..... Method # EC4

Method #	Sensor 1	Sensor 2		→Figure(s)
	Hall sensors	Digital incremental encoder	SSI / BiSS C unidirectional absolute encoder	
EC1	✓			5-42 5-43
EC2	✓	✓		5-42 5-43 5-44
EC3	✓		✓	5-42 5-43 5-45
EC4			✓	5-42 5-45

Table 5-51 Possible combinations of feedback signals for EC (BLDC) motor

5.2 Main wiring diagram

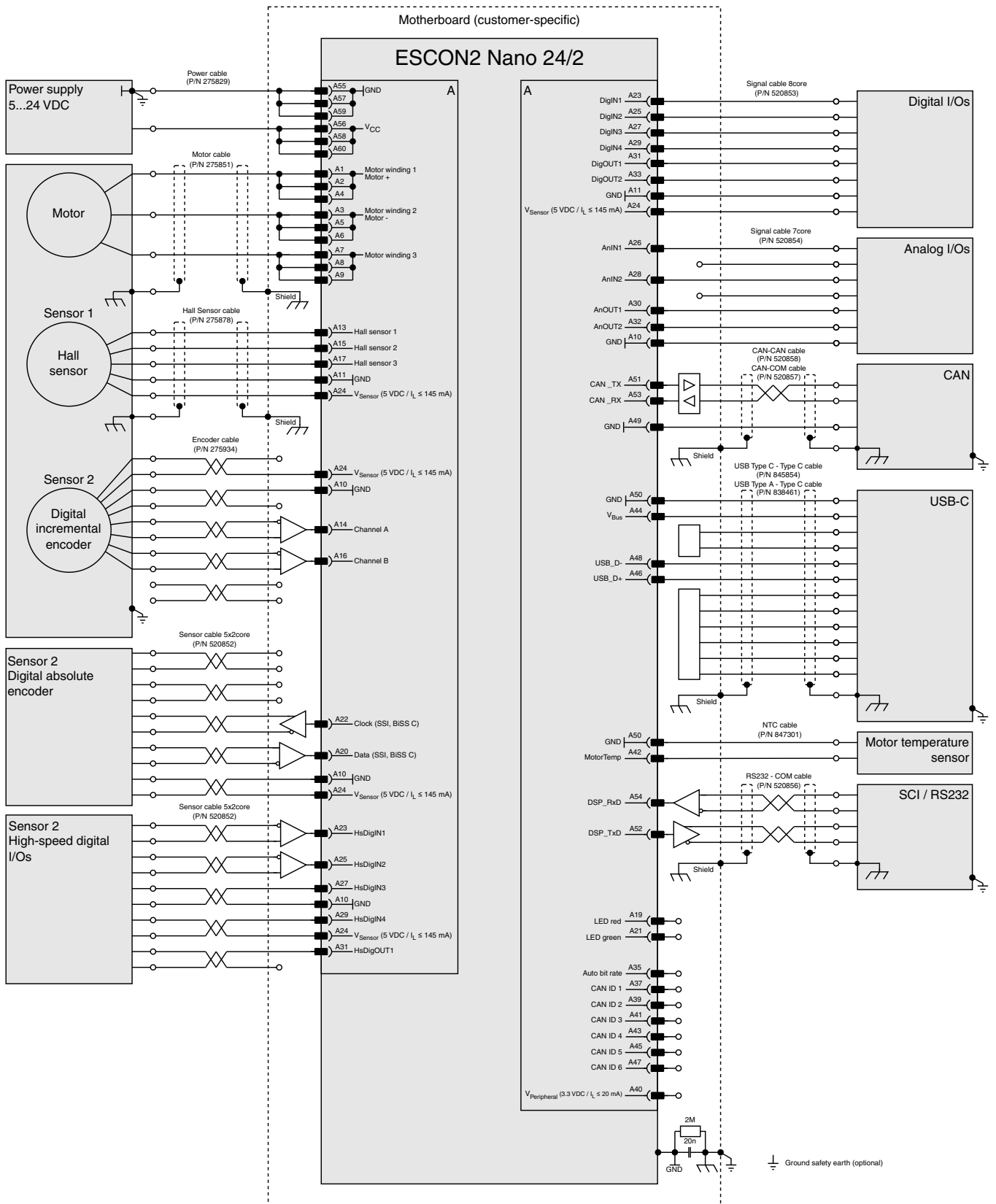

Figure 5-39 Main wiring diagram

### 5.3 Cabling

Utilize maxon's prefab cable assemblies to streamline your setup process. These ready-to-use cables can significantly reduce commissioning time. Refer to the table below for a list of compatible prefab cables and the corresponding connectors needed for motherboard installation.

For detailed information on these prefab cables, visit maxon's website and use the part number to access more information.

Designation	Prefab cable assembly			Required connector on motherboard (or similar)
	Part Number	For connection of external device Head B	For connection on motherboard Head A	
Power cable	275829	Wire end sleeves 0.75 mm <sup>2</sup>	Molex Mini-Fit Jr., 2 poles (39012020)	Molex Mini-Fit Jr., 2 poles (39281023)
Motor cable	275851	Wire end sleeves 0.75 mm <sup>2</sup>	Molex Mini-Fit Jr., 4 poles (39012040)	Molex Mini-Fit Jr., 4 poles (39281043)
Hall Sensor cable	275878	Wire end sleeves 0.14 mm <sup>2</sup>	Molex Micro-Fit 3.0, 6 poles (430250600)	Molex Micro-Fit 3.0, 6 poles (430450612)
Encoder cable	275934	DIN 41651 plug, pitch 2.54 mm, 10 poles	DIN 41651 female, pitch 2.54 mm, 10 poles	Amphenol ICC (52601-S10-8TLF)
Sensor cable 5×2core (for absolute encoder or high-speed digital I/Os)	520852	Wire end sleeves 0.14 mm <sup>2</sup>	Molex CLIK-Mate, 10 poles (5031491000)	Molex CLIK-Mate, 10 poles (5031481090)
Signal cable 8core (for digital I/Os)	520853	Wire end sleeves 0.14 mm <sup>2</sup>	Molex CLIK-Mate, 8 poles (5025780800)	Molex CLIK-Mate, 8 poles (5025840860)
Signal cable 7core (for analog I/Os)	520854	Wire end sleeves 0.14 mm <sup>2</sup>	Molex CLIK-Mate, 7 poles (5025780700)	Molex CLIK-Mate, 7 poles (5025840760)
CAN-CAN cable	520858	Molex CLIK-Mate, 4 poles (5025780400)	Molex CLIK-Mate, 4 poles (5025780400)	Molex CLIK-Mate, 4 poles (5025840470)
CAN-COM cable	520857	Female D-Sub connector DIN 41652, 9 poles	Molex CLIK-Mate, 4 poles (5025780400)	Molex CLIK-Mate, 4 poles (5025840470)
USB Type C – Type C cable	845854	USB Type C connector	USB Type C connector	Würth Elektronik (632722110112)
USB Type A – Type C cable	838461	USB Type A connector	USB Type C connector	Würth Elektronik (632722110112)
NTC cable	847301	Wire end sleeves 0.5 mm <sup>2</sup>	Molex Micro-Fit 3.0, 2 poles (430250200)	Molex Micro-Fit 3.0, 2 poles (430450212)
RS232 – COM cable	520856	Female D-Sub connector DIN 41652, 9 poles	Molex CLIK-Mate, 5 poles (5025780500)	Molex CLIK-Mate, 5 poles (5031750500)

Table 5-52 Prefab maxon cables

## 5.4 Excerpts

Depending on the connections, additional components are required to be installed on the motherboard. Detailed information can be found in →Chapter “4.2 Requirements for components of third-party suppliers” on page 4-39.

### 5.4.1 Power supply

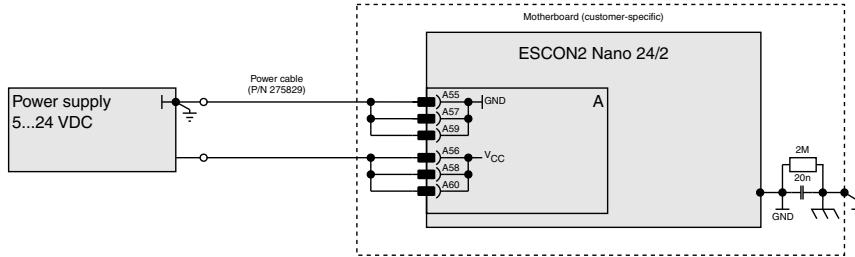

Figure 5-40 Power supply

For additional components that are recommended for installation on the motherboard refer to →Chapter “4.2.2 Power supply voltage” on page 4-40.

### 5.4.2 DC motor

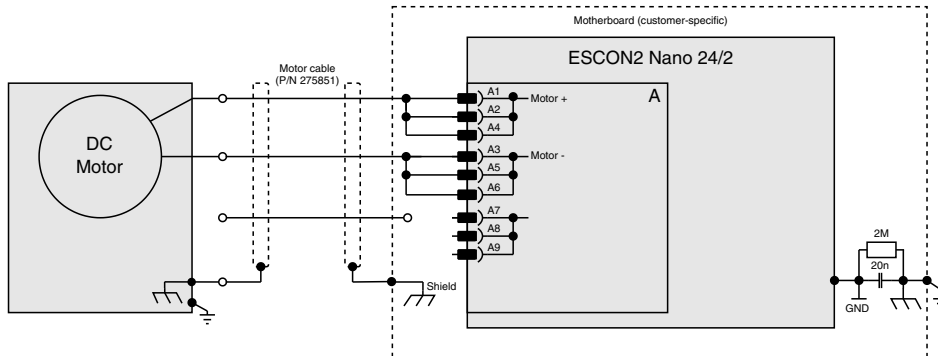

Figure 5-41 DC motor

For additional components that are recommended for installation on the motherboard refer to →Chapter “4.2.3 Motor chokes” on page 4-41.

### 5.4.3 EC (BLDC) motor

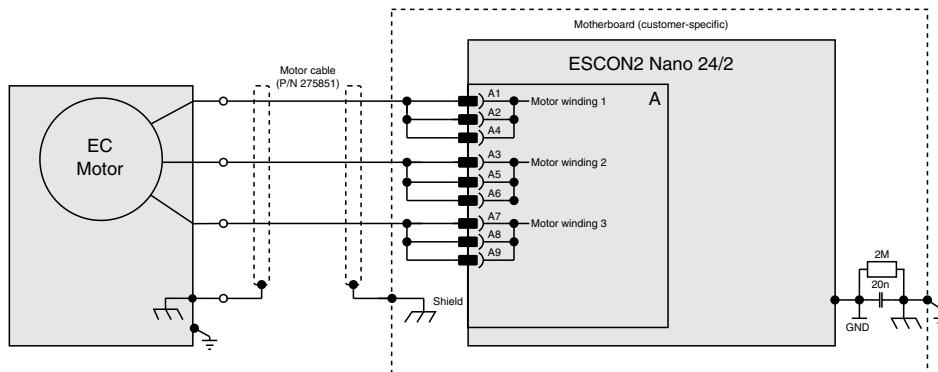

Figure 5-42 EC (BLDC) motor

For additional components that are recommended for installation on the motherboard refer to →Chapter “4.2.3 Motor chokes” on page 4-41.

**5.4.4 Sensor 1 Hall sensor**

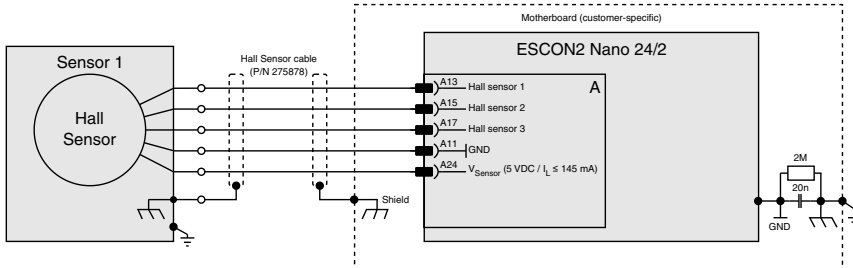

Figure 5-43 Sensor 1 Hall sensor

**5.4.5 Sensor 2 Encoder / I/Os**

**5.4.5.1 Digital incremental encoder**

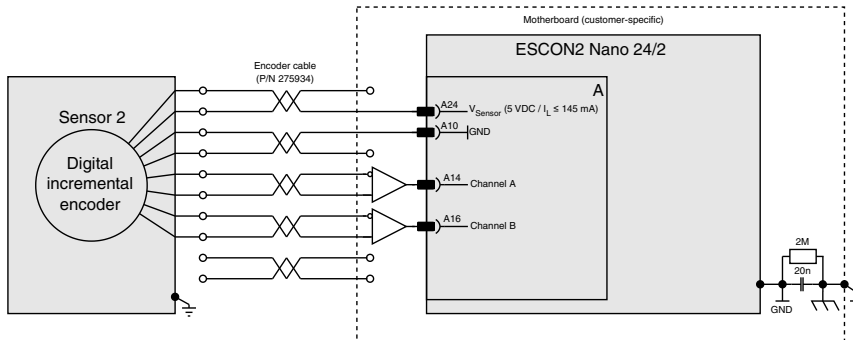

Figure 5-44 Digital incremental encoder

This interface can handle a digital incremental encoder, an SSI / BiSS C digital unidirectional absolute encoder or high-speed digital I/O's. Only one out of these three functions can be used at the same time.

**5.4.5.2 SSI / BiSS C unidirectional absolute encoder**

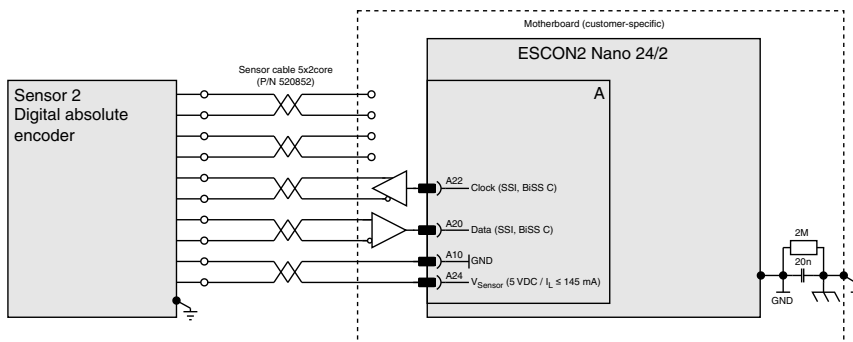

Figure 5-45 SSI / BiSS C unidirectional absolute encoder

An additional RS422 transceiver (line driver/receiver) is required on the motherboard for cable lengths over 30 cm or if differential signals shall be used. A wiring example is provided in →Chapter “4.2.8 RS422 transceiver for differential SSI, BiSS C or high-speed I/Os signals” on page 4-46.

This interface can handle a digital incremental encoder, an SSI / BiSS C digital unidirectional absolute encoder, or high-speed digital I/Os. Only one of these three functions can be used at a time.

5.4.5.3 High-speed digital I/Os

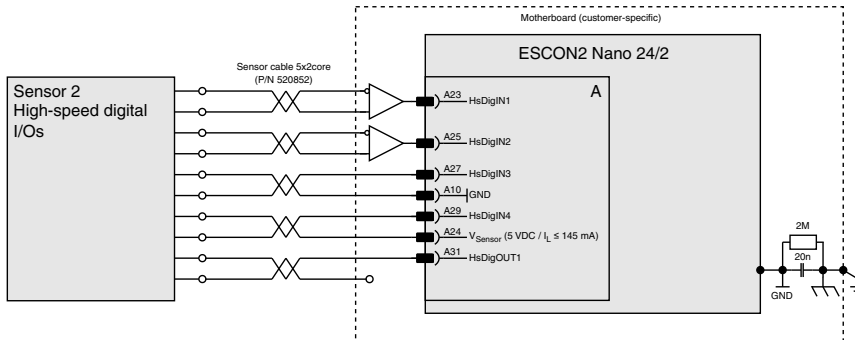

Figure 5-46 High-speed digital I/Os

An additional RS422 transceiver (line driver/receiver) is required on the motherboard if differential signals shall be used for HSDigIN3, HSDigIN4 or HSDigOUT1. A wiring example is provided in →Chapter “4.2.8 RS422 transceiver for differential SSI, BiSS C or high-speed I/Os signals” on page 4-46.

This interface can handle a digital incremental encoder, an SSI / BiSS C digital unidirectional absolute encoder or high-speed digital I/O's. Only one out of these three functions can be used at the same time.

5.4.6 Digital I/Os

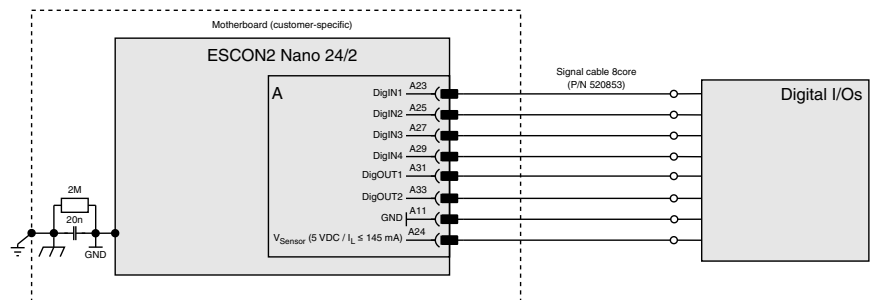

Figure 5-47 Digital I/Os

5.4.7 Analog I/Os

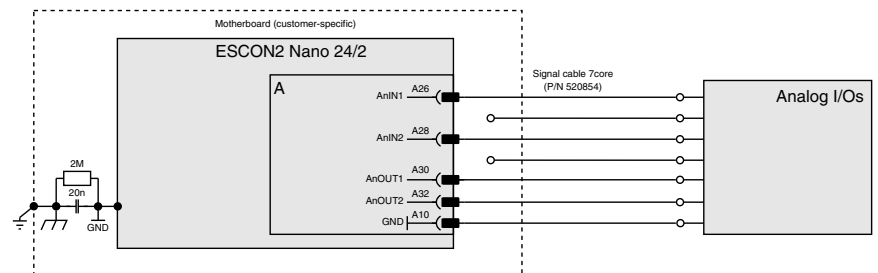

Figure 5-48 Analog I/Os

### 5.4.8 SCI / RS232

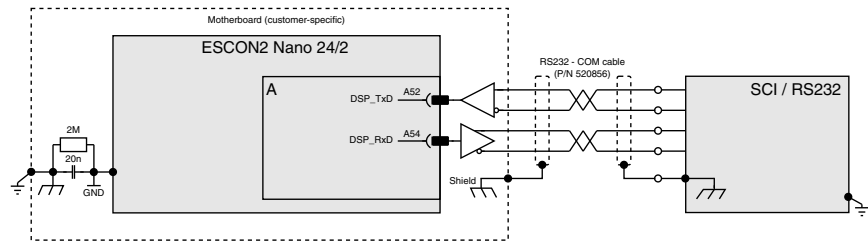

Figure 5-49 SCI / RS232

An additional RS232 transceiver (line driver/receiver) is necessary on the motherboard to use the serial communication interface with an external RS232 master. For board level operation, the serial interface can be used for direct connection. A wiring example is provided in →Chapter “4.2.6.2 RS232 interface” on page 4-44.

### 5.4.9 CAN

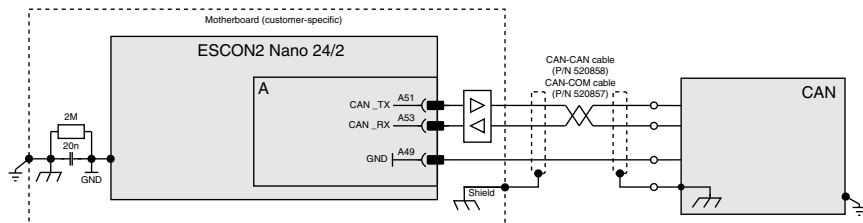

Figure 5-50 CAN

Depending on the preferred interface, one of the two prefab CAN cables can be used.

### 5.4.10 USB

#### 5.4.10.1 USB-C

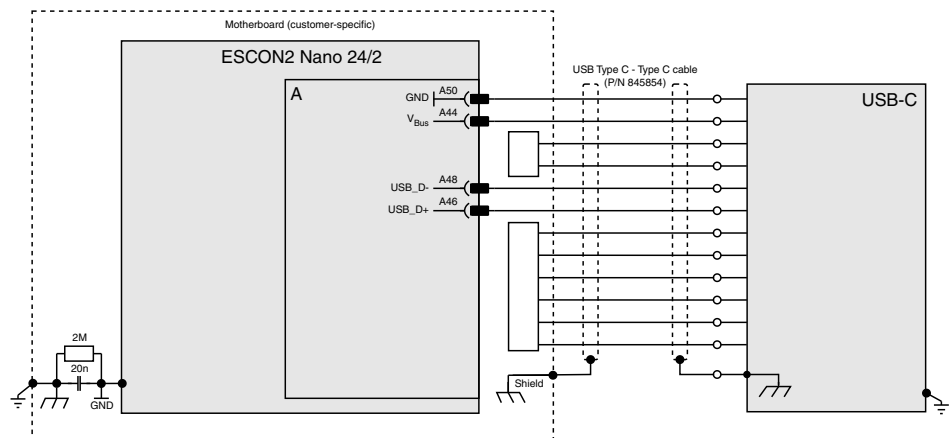

Figure 5-51 USB-C

The wiring above considers the installation of an USB-C connector with additionally required parts on the motherboard. Such a connector is required if the prefab cable shall be used. A wiring example is provided in →Chapter “4.2.4 USB interface” on page 4-42.

### 5.4.10.2 USB-A

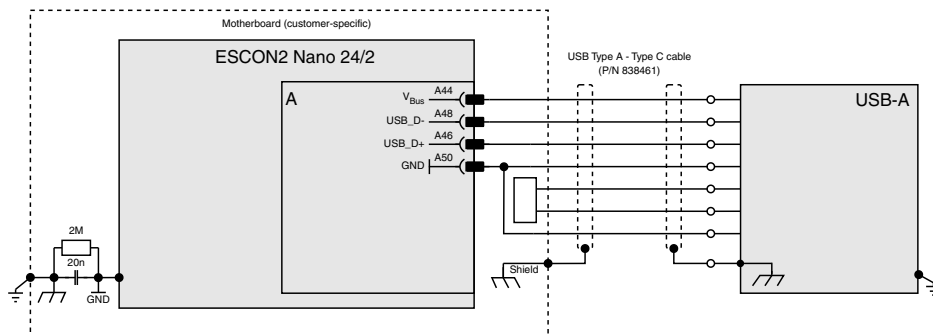

Figure 5-52 USB-A

The wiring above considers the installation of an USB-C connector with additionally required parts on the motherboard. Such a connector is required if the prefab cable shall be used. A wiring example is provided in [Chapter “4.2.4 USB interface”](#) on page 4-42.

### 5.4.11 Motor temperature sensor (future release)

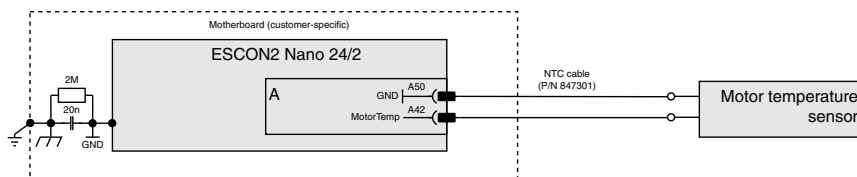

Figure 5-53 Motor temperature sensor

**••page intentionally left blank••**

## LIST OF FIGURES

Figure 1-1	Documentation structure . . . . .	5
Figure 2-2	Derating of output current (operation without additional heatsink) . . . . .	11
Figure 2-3	Extended operation @ VCC 24 VDC with additional heatsink . . . . .	12
Figure 2-4	Assembly with thermal accessories . . . . .	13
Figure 2-5	Power dissipation and efficiency . . . . .	13
Figure 2-6	Dimensional drawing [mm] . . . . .	14
Figure 3-7	Pin assignment . . . . .	18
Figure 3-8	Hall sensor 1 input circuit (analogously valid for Hall sensors 2 & 3) . . . . .	22
Figure 3-9	Digital incremental encoder input circuit Ch A "single-ended" (analogously valid for Ch B) . . . . .	24
Figure 3-10	SSI absolute encoder data input (analogously valid for BiSS C) . . . . .	25
Figure 3-11	SSI absolute encoder clock output (analogously valid for BiSS C) . . . . .	25
Figure 3-12	HsDigIN1 circuit "single-ended" (analogously valid for HsDigIN2...4) . . . . .	26
Figure 3-13	Wiring examples for proximity sensors and switches on HsDigIN1 (analogously valid for HsDigIN2..4) . . . . .	27
Figure 3-14	HsDigOUT1 circuit. . . . .	27
Figure 3-15	Wiring examples for "sourcing" on HsDigOUT1 . . . . .	27
Figure 3-16	DigIN1 circuit (analogously valid for DigIN2). . . . .	28
Figure 3-17	DigIN3 circuit (analogously valid for DigIN4). . . . .	29
Figure 3-18	Wiring examples for proximity sensors and switches on DigIN1 (analogously valid for DigIN2..4). . . . .	29
Figure 3-19	DigOUT1 circuit (analogously valid for DigOUT2). . . . .	30
Figure 3-20	Wiring examples for "sourcing" on DigOUT1 (analogously valid for DigOUT2) . . . . .	30
Figure 3-21	AnIN1 circuit (analogously valid for AnIN2). . . . .	31
Figure 3-22	Wiring examples for a potentiometer on AnIN1 (analogously valid for AnIN2) . . . . .	31
Figure 3-23	AnOUT1 circuit (analogously valid for AnOUT2). . . . .	32
Figure 3-24	SCI circuit . . . . .	33
Figure 3-25	Motor temperature circuit . . . . .	36
Figure 3-26	LED green circuit (analogously valid for LED red) . . . . .	37
Figure 4-27	Wiring of power supply . . . . .	40
Figure 4-28	Wiring of motor winding 1 (analogously valid for motor winding 2 & 3). . . . .	41
Figure 4-29	Wiring of USB-C connector . . . . .	42
Figure 4-30	Wiring of CAN interface . . . . .	43
Figure 4-31	Wiring of Serial Communication Interface (SCI) not used. . . . .	44
Figure 4-32	Wiring of RS232 interface . . . . .	44
Figure 4-33	Wiring of RS422 line receiver for incremental encoder or high-speed I/O signals . . . . .	45
Figure 4-34	Wiring of RS422 transceiver . . . . .	46
Figure 4-35	Wiring of digital output 1 load switch (analogously valid for digital output 2) . . . . .	46
Figure 4-36	Wiring of LEDs for device status indication . . . . .	47
Figure 4-37	SMT footprint [mm] – Top view . . . . .	51
Figure 5-38	Interfaces – Designations and location . . . . .	53
Figure 5-39	Main wiring diagram . . . . .	55
Figure 5-40	Power supply. . . . .	57
Figure 5-41	DC motor. . . . .	57

Figure 5-42	EC (BLDC) motor	57
Figure 5-43	Sensor 1 Hall sensor	58
Figure 5-44	Digital incremental encoder	58
Figure 5-45	SSI / BiSS C unidirectional absolute encoder	58
Figure 5-46	High-speed digital I/Os	59
Figure 5-47	Digital I/Os	59
Figure 5-48	Analog I/Os	59
Figure 5-49	SCI / RS232	60
Figure 5-50	CAN	60
Figure 5-51	USB-C	60
Figure 5-52	USB-A	61
Figure 5-53	Motor temperature sensor	61

## LIST OF TABLES

Table 1-1	Notations used in this document . . . . .	6
Table 1-2	Symbols and signs . . . . .	6
Table 1-3	Sources for additional information. . . . .	7
Table 2-4	Technical data . . . . .	10
Table 2-5	Heatsink – tested components . . . . .	12
Table 2-6	Thermal accessories – specification . . . . .	12
Table 2-7	Limitations . . . . .	14
Table 2-8	Standards . . . . .	15
Table 3-9	Pin assignment A1...A60 . . . . .	19
Table 3-10	Power supply – Pin assignment . . . . .	20
Table 3-11	Power supply requirements. . . . .	20
Table 3-12	Output voltages – Pin assignment. . . . .	21
Table 3-13	EC motor – Pin assignment. . . . .	21
Table 3-14	DC motor – Pin assignment . . . . .	21
Table 3-15	Hall sensor – Pin assignment . . . . .	22
Table 3-16	Hall sensor specification . . . . .	22
Table 3-17	Incremental encoder – Pin assignment. . . . .	23
Table 3-18	Single-ended digital incremental encoder specification . . . . .	23
Table 3-19	SSI / BiSS C unidirectional absolute encoder – Pin assignment. . . . .	24
Table 3-20	SSI / BiSS C unidirectional absolute encoder specification . . . . .	24
Table 3-21	Single-ended SSI / BiSS C unidirectional absolute encoder data channel specification. . . . .	25
Table 3-22	Single-ended SSI / BiSS C unidirectional absolute encoder clock channel specification . . . . .	25
Table 3-23	High-speed digital I/Os – Pin assignment . . . . .	26
Table 3-24	Single-ended high-speed digital input specification . . . . .	26
Table 3-25	High-speed digital output specification . . . . .	27
Table 3-26	Digital I/Os – Pin assignment . . . . .	28
Table 3-27	Digital inputs 1...2 specification. . . . .	28
Table 3-28	Digital inputs 3...4 specification. . . . .	29
Table 3-29	Digital output specification. . . . .	30
Table 3-30	Analog I/O – Pin assignment. . . . .	31
Table 3-31	Analog input specification . . . . .	31
Table 3-32	Analog output specification . . . . .	32
Table 3-33	SCI – Pin assignment . . . . .	32
Table 3-34	SCI specification . . . . .	33
Table 3-35	CAN – Pin assignment . . . . .	33
Table 3-36	CAN interface specification . . . . .	33
Table 3-37	CAN Auto bit rate / ID – Pin assignment . . . . .	34
Table 3-38	CAN ID specification . . . . .	34
Table 3-39	ID – Examples . . . . .	34
Table 3-40	Bit rate detection specification. . . . .	35
Table 3-41	USB – Pin assignment . . . . .	35

Table 3-42	USB interface specification . . . . .	35
Table 3-43	Motor temperature sensor – Pin assignment . . . . .	36
Table 3-44	Motor temperature sensor – specifications . . . . .	36
Table 3-45	Device Status LEDs . . . . .	37
Table 3-46	Device status outputs - Pin assignment . . . . .	37
Table 3-47	Device status output specification . . . . .	37
Table 4-48	Motherboard design guide – Recommended components . . . . .	50
Table 4-49	Motherboard design guide – Grounding . . . . .	50
Table 5-50	Possible combinations of feedback signals for DC motor . . . . .	54
Table 5-51	Possible combinations of feedback signals for EC (BLDC) motor . . . . .	54
Table 5-52	Prefab maxon cables . . . . .	56

## INDEX

### A

- alerts 6
  - CAUTION 6
  - DANGER 6
  - WARNING 6
- analog
  - inputs 31
  - outputs 32

### B

- BiSS C 24
- BiSS C unidirectional absolute encoder 25
- bit rate
  - (SCI) / RS232 32
  - CAN 34
  - default 32, 34
  - detection 35

### C

- CAN
  - bit rate 34
  - bus termination 34
  - ID (see "ID")
  - interface 33
- choke, motor 9, 41
- codes (used in this document) 6
- country-specific regulations 8

### D

- digital
  - inputs 28, 29
  - outputs 30
- digital high-speed
  - inputs (single-ended) 26
  - output 27
- digital incremental encoder (single-ended) 23
- directive EU, applicable 17

### E

- encoders
  - absolute 24
  - incremental 23
  - single-ended 24
  - SSI / BiSS C unidirectional absolute encoder 24
- ESD 8
- EU directive, applicable 17

### H

- Hall sensor 22
- high-speed digital
  - inputs (single-ended) 26
  - output 27
- how to
  - calculate the required supply voltage 20

- get help in designing the motherboard 39
- interpret icons (and signs) used in this document 6

### I

- ID (of the device) 35
- incorporation into surrounding system 17
- informatory signs 6
- inputs
  - (single-ended) 26
  - analog 31
  - digital 28, 29
  - high-speed digital 26
- interfaces
  - CAN 33
  - designation and location 53
  - serial communication interface (SCI) / RS232 32
  - USB 35
- internal motor chokes 9, 41

### L

- LED 37

### M

- mandatory action signs 6
- motor choke 9, 41
- motor connection 21
- motor temperature sensor 36

### N

- Node-ID (see "ID")
- notations (used in this document) 6

### O

- outputs
  - analog 32
  - digital 30
  - high-speed digital 27

### P

- part numbers
  - 309687 47
  - 809635 9, 10
  - 834838 7, 10, 39
  - 876085 12
- performance data 9
- pin assignment 18
- power supply 20
- precautions 8
- prerequisites prior installation 17
- prohibitive signs 6
- purpose
  - of the device 7
  - of the document 5

**R**

RS232 transceiver 44

**S**

safety alerts 6

safety first! 8

SCI 32, 33

bit rate 32

Serial Communication Interface 44, 60

serial encoder 24

signs used 6

SSI 24

SSI absolute encoder 25

standards, fulfilled 15

status LEDs 37

supply voltage, required 20

symbols used 6

**T**

technical data 9

termination (CAN bus) 34

**U**

USB 35

**W**

wiring examples

analog I/Os 59

CAN 60

DC motor 57

digital I/Os 59

digital incremental encoder 58

EC (BLDC) motor 57

high-speed digital I/Os 59

motor temperature sensor 61

power supply 57

SCI / RS232 60

sensor 1 hall sensor 58

sensor 2 encoder I/Os 58

SSI / BiSS C unidirectional absolute encoder 58

USB 60

USB-A 61

USB-C 60

••page intentionally left blank••

