

4.3 Excerpts

4.3.1 Power supply

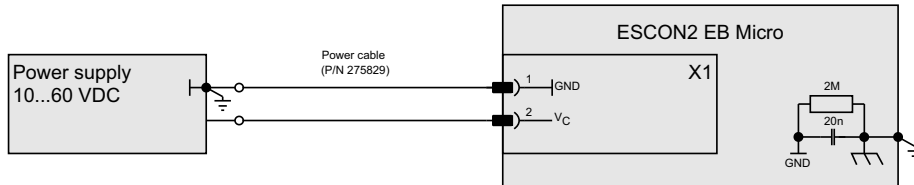

Figure 4-44 Power supply

4.3.2 Logic supply

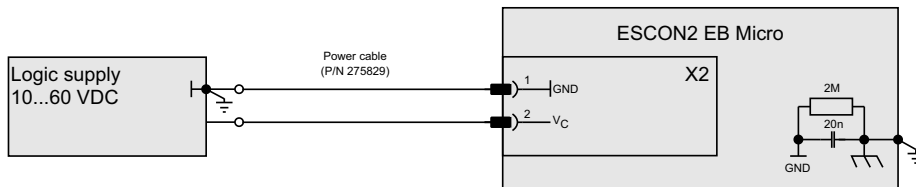

Figure 4-45 Logic supply

4.3.3 DC motor

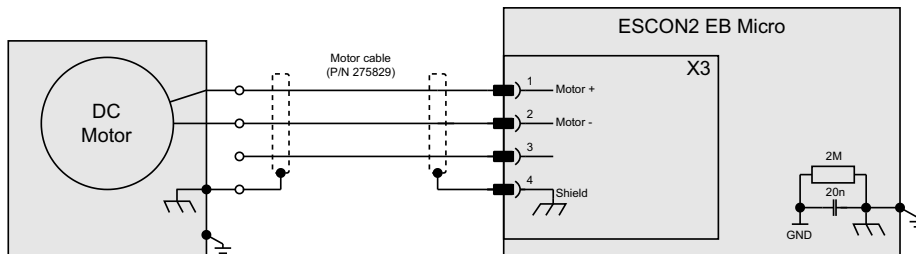

Figure 4-46 DC motor

4.3.4 EC (BLDC) motor

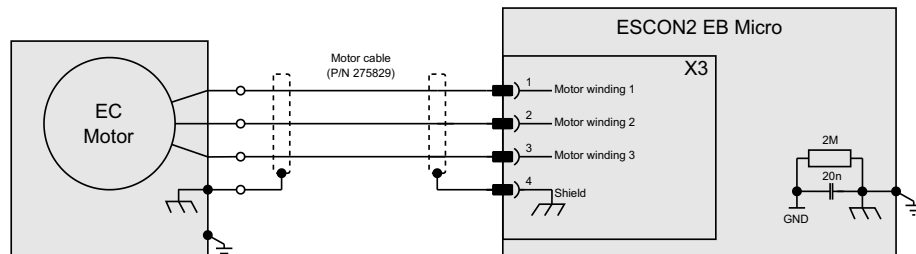

Figure 4-47 EC (BLDC) motor

4.3.5 Sensor 1 Hall sensor

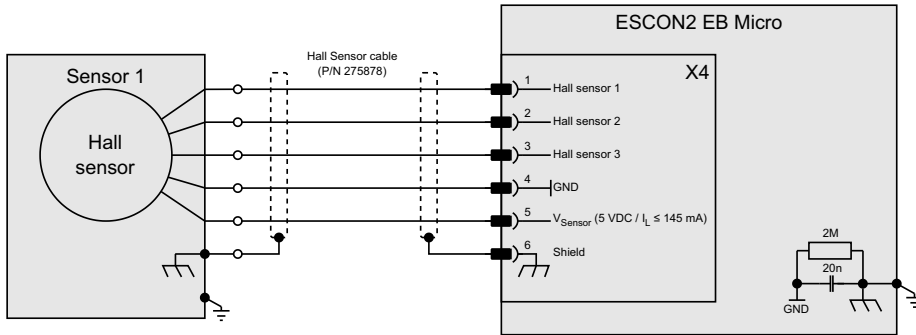

Figure 4-48 Sensor 1 Hall sensor

4.3.6 Sensor 2 Encoder / I/Os

4.3.6.1 Digital incremental encoder

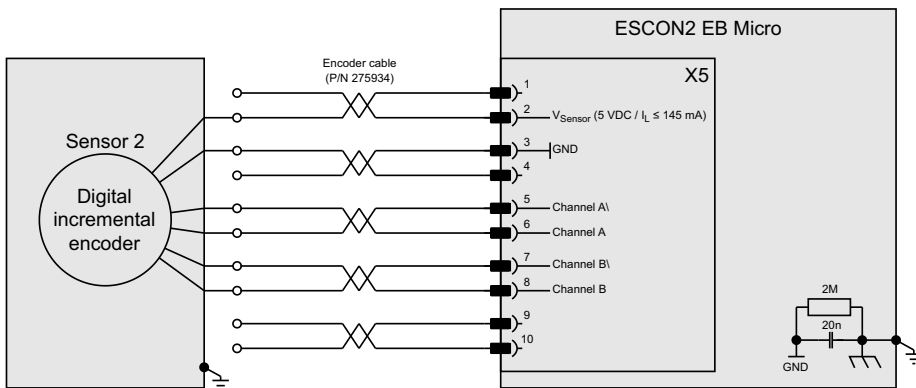

Figure 4-49 Digital incremental encoder

This interface can handle a digital incremental encoder, an SSI / BiSS C digital unidirectional absolute encoder or high-speed digital I/O's. Only one out of these three functions can be used at the same time.

4.3.6.2 SSI / BiSS C unidirectional absolute encoder

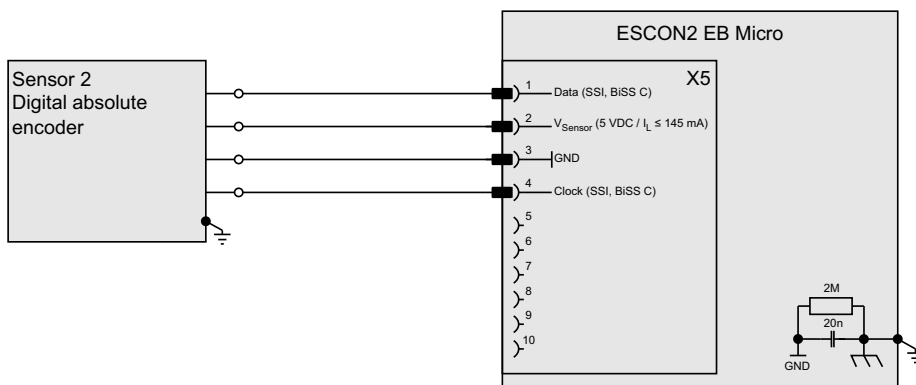

Figure 4-50 SSI / BiSS C unidirectional absolute encoder

This interface can handle a digital incremental encoder, an SSI / BiSS C digital unidirectional absolute encoder or high-speed digital I/O's. Only one out of these three functions can be used at the same time.

4.3.6.3 High-speed digital I/Os

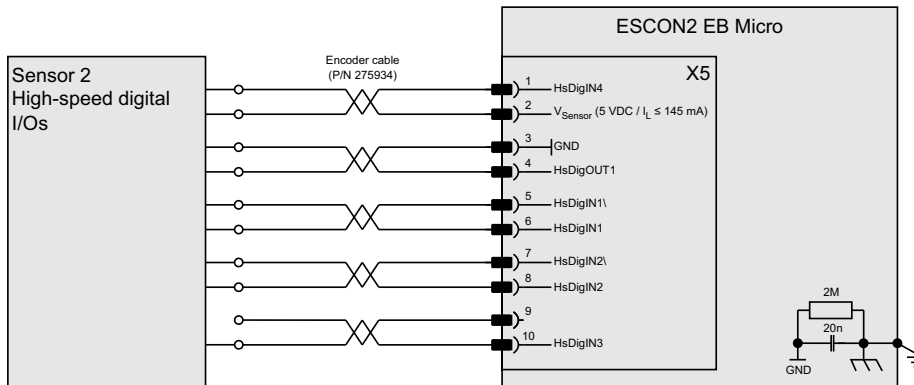

Figure 4-51 High-speed digital I/Os

This interface can handle a digital incremental encoder, an SSI / BiSS C digital unidirectional absolute encoder or high-speed digital I/O's. Only one out of these three functions can be used at the same time.

4.3.7 Digital I/Os

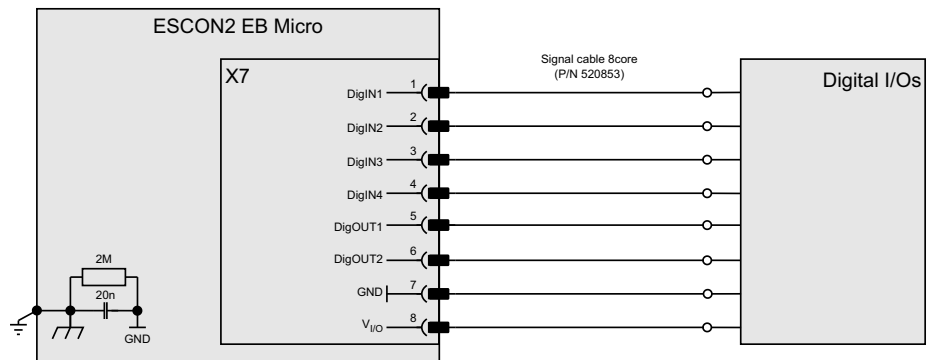

Figure 4-52 Digital I/Os

4.3.8 Analog I/Os

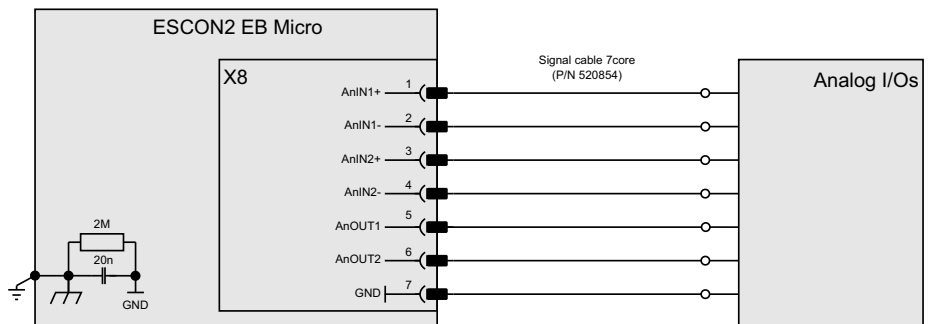

Figure 4-53 Analog I/Os

4.3.9 RS232

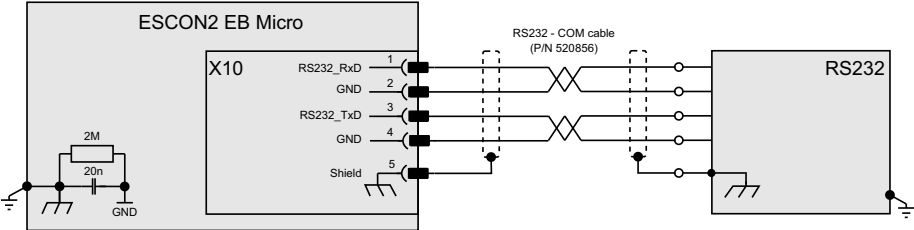

Figure 4-54 RS232

4.3.10 CAN

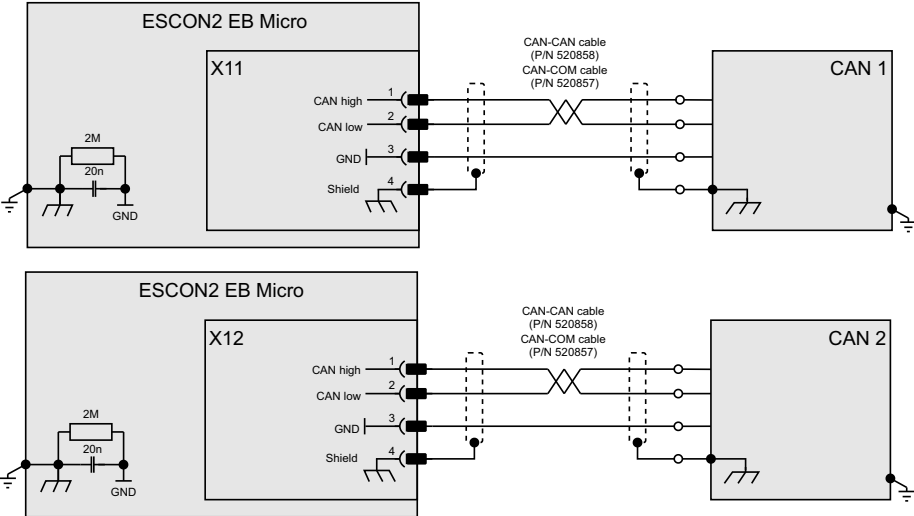

Figure 4-55 CAN

Depending on the preferred interface, one of the two prefab CAN cables can be used.

4.3.11 USB

4.3.11.1 USB-C

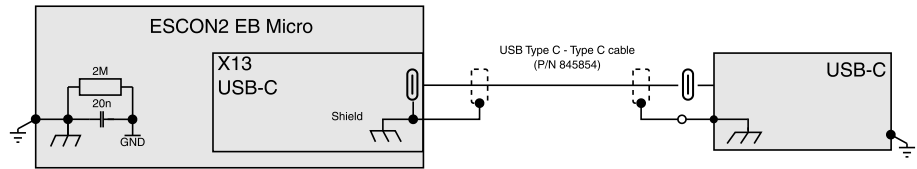

Figure 4-56 USB-C

4.3.11.2 USB-A

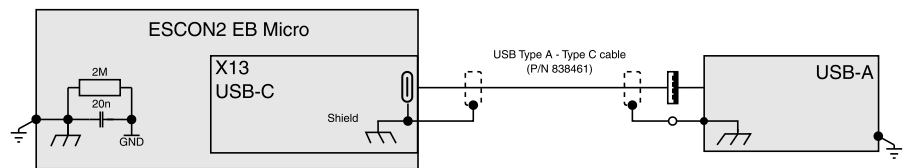

Figure 4-57 USB-A

4.3.12 Motor temperature sensor (future release)

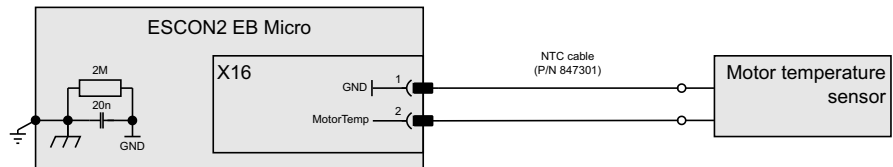

Figure 4-58 Motor temperature sensor

LIST OF FIGURES

Figure 1-1	Documentation structure	5
Figure 2-2	Derating of output current (operation without additional heatsink)	11
Figure 2-3	Extended operation @ VCC 60 VDC with additional heatsink	12
Figure 2-4	Assembly with thermal accessories	13
Figure 2-5	Power dissipation and efficiency	13
Figure 2-6	Dimensional drawing [mm]	14
Figure 3-7	Connections	18
Figure 3-8	Power supply connector X1	20
Figure 3-9	Logic supply connector X2	21
Figure 3-10	Motor connector X3	22
Figure 3-11	Sensor 1 Hall sensor connector X4	23
Figure 3-12	Sensor 1 Hall sensor input circuit (analogously valid for Hall sensors 2 & 3)	24
Figure 3-13	Sensor 2 connector X5	25
Figure 3-14	Digital incremental encoder input circuit Ch A “differential” (analogously valid for Ch B)	26
Figure 3-15	Digital incremental encoder input circuit Ch A “single-ended” (analogously valid for Ch B)	27
Figure 3-16	SSI absolute encoder data input (analogously valid for BiSS C)	28
Figure 3-17	SSI absolute encoder clock output (analogously valid for BiSS C)	29
Figure 3-18	HsDigIN1 circuit “differential” (analogously valid for HsDigIN2)	30
Figure 3-19	HsDigIN1 circuit “single-ended” (analogously valid for HsDigIN2...3)	31
Figure 3-20	HsDigIN4 circuit “single-ended”	31
Figure 3-21	Wiring examples for proximity sensors and switches on HsDigIN1 (analogously valid for HsDigIN2)	32
Figure 3-22	HsDigOUT1 circuit	32
Figure 3-23	Wiring examples for “sourcing” on HsDigOUT1	33
Figure 3-24	Digital I/Os connector X7	33
Figure 3-25	DigIN1 circuit (analogously valid for DigIN2)	34
Figure 3-26	DigIN3 circuit (analogously valid for DigIN4)	35
Figure 3-27	Wiring examples for proximity sensors and switches on DigIN1 (analogously valid for DigIN2..4)	35
Figure 3-28	DigOUT1 circuit with wiring example for “sinking” inductive loads (analogously valid for DigOUT2)	36
Figure 3-29	DigOUT1 circuit with wiring examples for “sinking” general-purpose loads (also valid for DigOUT2)	37
Figure 3-30	DigOUT1 circuit with wiring examples for “sourcing” (analogously valid for DigOUT2)	37
Figure 3-31	Analog I/Os connector X8	38
Figure 3-32	AnIN1 circuit (analogously valid for AnIN2)	39
Figure 3-33	Wiring examples for a potentiometer on AnIN1 (analogously valid for AnIN2)	39
Figure 3-34	AnOUT1 circuit (analogously valid for AnOUT2)	40
Figure 3-35	RS232 connector X10	40
Figure 3-36	CAN 1 connector X11/CAN 2 connector X12	41
Figure 3-37	USB connector X13	42
Figure 3-38	Motor temperature sensor connector X16	43
Figure 3-39	Motor temperature circuit	44
Figure 3-40	DIP switch SW1	45
Figure 3-41	LEDs – Location	48

Figure 4-42	Interfaces – Designations and location	49
Figure 4-43	Main wiring diagram	51
Figure 4-44	Power supply	52
Figure 4-45	Logic supply	52
Figure 4-46	DC motor	52
Figure 4-47	EC (BLDC) motor	52
Figure 4-48	Sensor 1 Hall sensor	53
Figure 4-49	Digital incremental encoder	53
Figure 4-50	SSI / BiSS C unidirectional absolute encoder	53
Figure 4-51	High-speed digital I/Os	54
Figure 4-52	Digital I/Os	54
Figure 4-53	Analog I/Os	54
Figure 4-54	RS232	55
Figure 4-55	CAN	55
Figure 4-56	USB-C	56
Figure 4-57	USB-A	56
Figure 4-58	Motor temperature sensor	56

LIST OF TABLES

Table 1-1	Notations used in this document	6
Table 1-2	Symbols and signs	6
Table 1-3	Sources for additional information.	7
Table 2-4	Technical data	10
Table 2-5	Heatsink – tested components	12
Table 2-6	Thermal accessories – specification	12
Table 2-7	Limitations	14
Table 2-8	Standards	15
Table 3-9	Prefab maxon cables.	19
Table 3-10	Motion connector set – Content	19
Table 3-11	Recommended tools	19
Table 3-12	Power supply connector X1 – Pin assignment	20
Table 3-13	Power cable.	20
Table 3-14	Power supply requirements.	20
Table 3-15	Logic supply connector X2 – Pin assignment	21
Table 3-16	Power cable.	22
Table 3-17	Logic supply requirements	22
Table 3-18	Motor connector X3 – Pin assignment for maxon EC & DC motor	22
Table 3-19	Motor cable	23
Table 3-20	Hall sensor connector X4 – Pin assignment	23
Table 3-21	Hall sensor cable.	23
Table 3-22	Sensor 1 Hall sensor specification	24
Table 3-23	Sensor 2 connector X5 – Pin assignment.	25
Table 3-24	Encoder cable	25
Table 3-25	Differential digital incremental encoder specification	26
Table 3-26	Single-ended digital incremental encoder specification	27
Table 3-27	SSI / BiSS C unidirectional absolute encoder specification	27
Table 3-28	Single-ended SSI / BiSS C unidirectional absolute encoder data channel specification.	28
Table 3-29	Single-ended SSI / BiSS C unidirectional absolute encoder clock channel specification	28
Table 3-30	Encoder cable	29
Table 3-31	Differential high-speed digital inputs specification.	29
Table 3-32	Single-ended high-speed digital inputs specification.	30
Table 3-33	High-speed digital output specification	32
Table 3-34	Digital I/Os connector X7 – Pin assignment	33
Table 3-35	Signal cable 8core.	34
Table 3-36	Digital inputs 1...2 specification	34
Table 3-37	Digital inputs 3...4 specification	35
Table 3-38	Digital outputs specification – Sinking.	36
Table 3-39	Digital outputs specification – Sourcing.	37
Table 3-40	Analog I/Os connector X8 – Pin assignment.	38
Table 3-41	Signal cable 7core.	38

Table 3-42	Analog input specification	38
Table 3-43	Analog output specification	39
Table 3-44	RS232 connector X10 – Pin assignment	40
Table 3-45	RS232-COM cable	40
Table 3-46	RS232 interface specification	41
Table 3-47	CAN 1 connector X11/CAN 2 connector X12 – Pin assignment	41
Table 3-48	CAN-CAN cable	41
Table 3-49	CAN-COM cable	42
Table 3-50	CAN interface specification	42
Table 3-51	USB Type C – Type C cable	43
Table 3-52	USB Type A – Type C cable	43
Table 3-53	USB interface specification	43
Table 3-54	Motor temperature sensor connector X16 – Pin assignment	44
Table 3-55	NTC cable	44
Table 3-56	Motor temperature sensor – specifications	44
Table 3-57	DIP switch SW1 – Binary code values	45
Table 3-58	DIP switch SW1 – Examples	46
Table 3-59	DIP switch SW1 – CAN automatic bit rate detection	47
Table 3-60	DIP switch SW1 – CAN bus termination	47
Table 3-61	Device status LEDs	48
Table 4-62	Possible combinations of feedback signals for DC motor	50
Table 4-63	Possible combinations of feedback signals for EC (BLDC) motor	50

INDEX

A

- alerts 6
 - CAUTION 6
 - DANGER 6
 - WARNING 6
- analog
 - inputs 38
 - outputs 39

B

- BiSS C 27
- BiSS C unidirectional absolute encoder 28
- bit rate
 - CAN 42
 - default 41, 42
 - detection 47
 - RS232 41

C

- cables (prefab)
 - CAN-CAN cable 41
 - CAN-COM cable 42
 - Encoder cable 25, 29
 - Hall sensor cable 23
 - Motor cable 23
 - NTC cable 44
 - Power cable 20, 22
 - RS232-COM cable 40
 - Signal cable 7core 38
 - Signal cable 8core 34
 - USB Type A - Type C cable 43
 - USB Type C - Type C cable 43

CAN

- bit rate 42
- bus termination 42, 47
- ID (see "ID")
- interface 42
- choke, motor 9
- codes (used in this document) 6
- connections 18
- connector set 19
- connectors
 - X1 20
 - X10 40
 - X11 41
 - X12 41
 - X13 42
 - X16 43
 - X2 21
 - X3 22
 - X4 23
 - X5 24
 - X7 33
 - X8 38
- country-specific regulations 8

D

- digital
 - inputs 34, 35
 - outputs 36, 37
- digital high-speed
 - inputs (differential) 29
 - inputs (single-ended) 30
 - output 32
- digital incremental encoder
 - (differential) 26
 - (single-ended) 27
- DIP switch SW1 45
- directive EU, applicable 17

E

- encoders
 - absolute 27
 - incremental 26
 - single-ended 27
 - SSI / BiSS C unidirectional absolute encoder 27
- ESD 8
- EU directive, applicable 17

H

- Hall sensor 23, 24
- high-speed digital
 - inputs (differential) 29
 - inputs (single-ended) 30
 - output 32
- how to
 - calculate the required supply voltage 21
 - interpret icons (and signs) used in this document 6

I

- ID (of the device) 45
- incorporation into surrounding system 17
- Incremental encoder 26
- informatory signs 6
- inputs
 - (differential) 29
 - (single-ended) 30
 - analog 38
 - digital 34, 35
 - high-speed digital 29
- interfaces
 - CAN 1 41
 - CAN 2 41
 - designation and location 49
 - RS232 40
 - USB 42, 43
- internal motor chokes 9

L

- LED 48

M

mandatory action signs 6
Motion connector set 19
motor choke 9
motor connection 22

N

Node-ID (see "ID")
notations (used in this document) 6

O

outputs
 analog 39
 digital 36, 37
 high-speed digital 32

P

part numbers
 275829 20, 22
 275851 23
 275878 23
 275934 25, 29
 520853 34
 520854 38
 520856 40
 520857 42
 520858 41
 809631 7, 9, 10, 12
 809646 9, 10
 838461 43
 841890 12
 845854 43
 846644 19
 847301 44
performance data 9
pin assignment 20
power supply 20
precautions 8
prerequisites prior installation 17
prohibitive signs 6
purpose
 of the device 7
 of the document 5

R

RS232 40

S

safety alerts 6
safety first! 8
serial encoder 27
signs used 6
SSI 27
SSI absolute encoder 28
standards, fulfilled 15
status LEDs 48
supply voltage, required 21
SW1 45
symbols used 6

T

technical data 9
termination (CAN bus) 42, 47

U

USB 42

W

wiring examples
 analog I/Os 54
 CAN 55
 DC motor 52
 digital I/Os 54
 digital incremental encoder 53
 EC (BLDC) motor 52
 high-speed digital I/Os 54
 logic supply 52
 motor temperature sensor 56
 power supply 52
 RS232 55
 sensor 1 hall sensor 53
 sensor 2 encoder I/Os 53
 SSI / BiSS C unidirectional absolute encoder 53
 USB-A 56
 USB-C 56

••page intentionally left blank••

